

# 708HP Series

## Fractional Flow Control Valves

### FRACTIONAL FLOW CONTROL VALVES

The Mark 708HP is an 8,000 psi (552 bar) maximum inlet fractional flow control valve. This rugged, compact control valve is suitable for a variety of industrial and research applications. It is ideal for offshore chemical injection, hydrocarbon processing, chemical processing, high effort hydraulic actuators and many other high pressure applications. Linear and equal percentage flow characteristics are available with Cv's ranging from 0.05 (0,04 Kv) to 1.25 (1,1 Kv). In addition, the Mark 708HP is available in a variety of end connections and optional materials of construction making it a versatile solution to your demanding valve requirements.

#### Features:

- Union style body / bonnet connection – provides solid construction and secure connection. The metal 'C' ring gasket provides excellent sealing without exposing the bonnet threads to the media. Adds ease to maintenance, as bonnet and actuator assembly may be removed with the body in-line.
- Mechanically loaded PTFE Chevron heavy duty V ring packing – the adjustable packing arrangement maintains a proper compression, while minimizing excessive friction. The PTFE packing is suitable for temperature to 450°F (232°C), while mechanically loaded Graphoil may be used for higher temperature requirements.
- Rolling diaphragm – the rolling diaphragm design ensures that the effective diaphragm area remains relatively constant, regardless of valve stem position. This increases accuracy of the actuator while positioning the valve by ensuring a linear response to input signal changes.
- Guided trim – extended orifice and plug guiding are standard and offers improved shutoff and accuracy.
- Standard with side mount positioner



A Division of  
Richards Industrials  
3170 Wasson Road  
Cincinnati, OH 45209

lowflow@richardsind.com  
513.533.5600  
www.lowflowvalve.com

### MK708HP SERIES SPECIFICATIONS

Sizes: 1/2" (DN15)

#### End Connections

- Threaded – FNPT
- Socket weld

#### Actuator

- 35M (35 in<sup>2</sup>)

#### Diaphragm Material

- Buna-N fabric reinforced

#### Body/Bonnet Materials

- 316/316L Stainless Steel barstock
- Monel barstock
- Alloy 20 barstock

#### Trim Materials

- Stellite Plug/Seat and Nitronic 60 Stem

#### Actuator Materials

- Steel – 35M

#### Stem Packing

- PTFE Chevron Heavy duty V ring - mechanically loaded
- Optional: Graphite/Graphoil - mechanically loaded

**Body/Bonnet Gasket:** Parker Seals Metal 'C' Ring Inconel X-750

**Service:** steam, air, gas, oil, water, chemicals

#### Maximum Operating Pressure:

- 8000 psi max inlet @ 100°F (552 bar max inlet @ 38°C)
- 7530 psi (519 bar) max ΔP ATC with positioner and 45 psig (3,1 bar) supply
- 5875 psi (405 bar) max ΔP ATO with positioner and 45 psig (3,1 bar) supply

#### Maximum Operating Temperature:

- 2680 psi (185 bar) max inlet @ 850°F (454°C) with Graphite/Graphoil packing
- 6580 psig (454 bar) max inlet @ 450°F (232°C) with TFE packing

#### Shutoff:

- Standard – Cv's 0.05 and greater: ANSI Class IV

For other options/materials, consult factory

### MK708HP SERIES BODY/BONNET CONNECTION

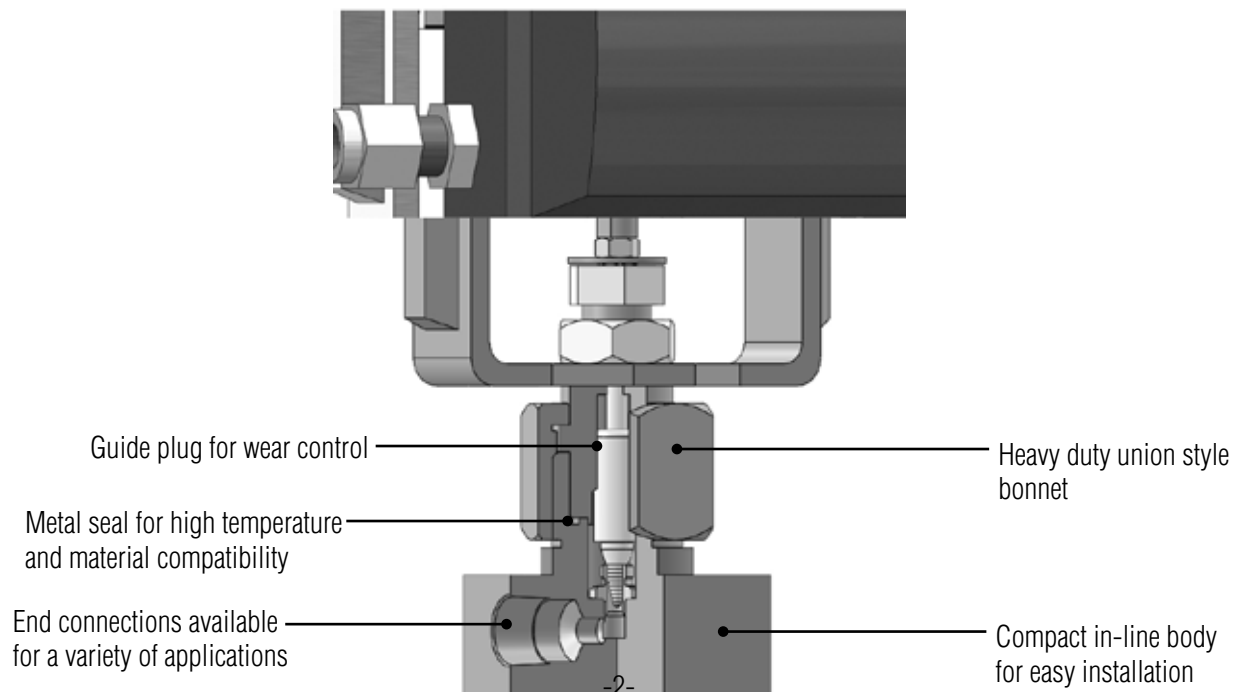

**MK708HP SERIES DIMENSIONS**

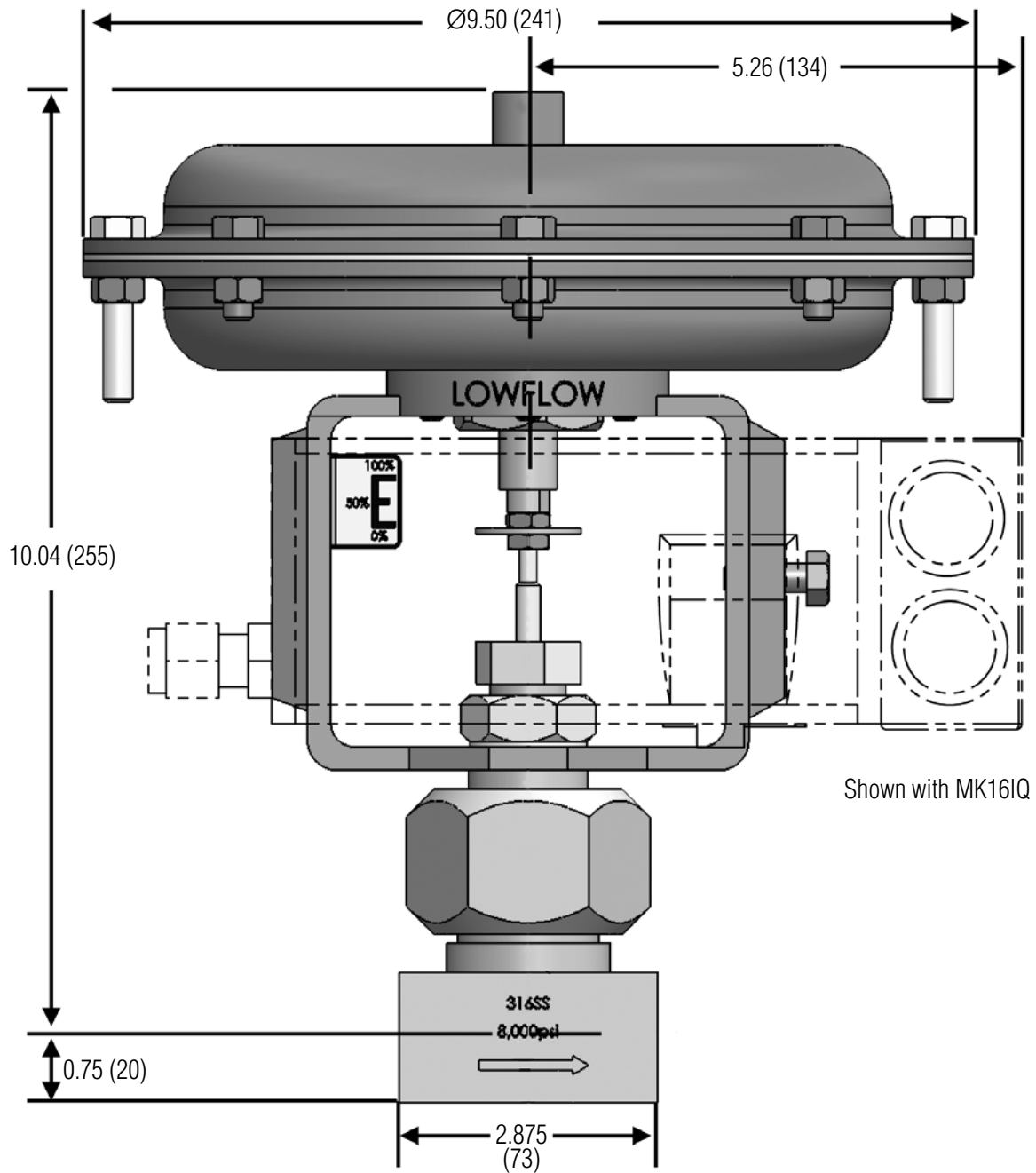



## ORDER SCHEMATICS

## MK708HP SERIES ORDERING SCHEMATIC

Model No.	Size	Body Mat'l	1	2	3	4	5	6	7	8	9	10	11	12	13	14	15	16	17

MODEL	
708HP	Standard

SIZE	
050	1/2" (DN15)

BODY MATERIAL	
SB	Stainless Steel (316/316L)
HC	Hastelloy C
MN	Monel
A2	Alloy 20

1 & 2 END CONNECTIONS	
PT	NPT
SW	Socket Weld
TN	Integral Tube Nuts
ZZ	Non-standard

3 & 4 TRIM	
T6	Teflon Packing
G6	Graphite/Graphoil
ZZ	Non-standard

5 & 6 PLUG SEAT			
	Material of Stem/Plug/Seat		Cv
M	316/Stellite/Stell-Lin. Hard	L	0.05
N	316/Stellite/Stell =% Hard	M	0.10
		N	0.20
		P	0.50
		Q	1.0
		W	1.25
ZZ	Non-standard		

7 & 8 RANGE			
	Range	Actuator	
A	Direct	3	35M
B	Reverse		
ZZ	Non-standard		

9 & 10 DIAPHRAGM			
	Material	Size	
B	Buna-N	3	35M
ZZ	Non-standard		

11 & 12 ACTUATOR			
	Type	Size	
S	With SMP	3	35M
ZZ	Non-standard		

13 & 14 ACCESSORIES	
00	None
AR	Air Regulator
S2	3-way Solenoid Energize to Open
S3	3-way Solenoid Energize to Close
ZZ	Non-standard

15 ACTION	
D	Air-to-close
R	Air-to-open

16 I/P	
0	None

17 SMP	
0	None
A	MK16 SMP Dir/Rev 3-15
B	MK16 SMP Dir/Rev 3-9
C	MK16 SMP Dir/Rev 9-15
D	MK16 SMP/IP Dir/Rev 4-20
E	MK16 SMP/IP Dir/Rev 4-12
F	MK16 SMP/IP Dir/Rev 12-20
G	MK 16IQ-S Dir/Rev 4-20
H	MK16IQ-B Dir/Rev 4-20
J	MK16IQ-FF Dir/Rev 4-20
Z	Non-standard