



Mark 5800HP Series

High Back Pressure Regulator

CRN Registration Number Available

HIGH BACK PRESSURE REGULATORS

The Mark 5800HP is a high pressure, back pressure regulator designed to maintain upstream pressure of gases and liquids. As a compact, lightweight product, it is well suited for applications where space and weight are at a premium.

With a robust, piston design, the MK5800HP can handle setpoints up to 2500 psig (172 bar) at 450°F (232°C) with ease and the large flow capacity for a valve of this style is among the highest in the industry. The T-bar adjusting handle allows for a lighter spring and more sensitive regulator than those models with a fixed knob. This added sensitivity contributes greatly to the accuracy of the valve.

The valve is normally closed, with the soft seat maintaining ANSI Class VI shutoff. When the inlet rises above the spring setpoint, the pressure forces the piston upwards to open and relieve the pressure. As the inlet pressure falls to the spring setpoint level, the valve then throttles closed to ensure the pressure doesn't drop below the spring setpoint.

Among other applications, the MK5800HP can be used for:

- high pressure vessel venting
- high pressure injection applications
- gas/liquid sampling stations
- compressor skids
- test standards

Features:

- Complete barstock construction – ensures body/trim material quality and facilitates usage of alloy materials
- High flow – Cv 1.0 (Kv 0,9) in a compact design
- Full pressure rating across entire temperature range – maximum setpoints available at maximum pressures
- T-bar handle – permits usage of lighter, more sensitive spring
- Proof-tested to 12,000 psi (827 bar) – nearly five times pressure rating, ensures safety when working with high pressures
- A variety of seal materials ensure compatibility with medium setpoint



A Division of
Richards Industrials
3170 Wasson Road
Cincinnati, OH 45209

513.533.5600
lowflow@richardsind.com

www.lowflowvalve.com

MK5800HP HIGH BACK PRESSURE REGULATOR
SPECIFICATIONS

Line Size: 1/2", 3/4", 1" (DN15, DN20, DN25)

End Connections

- Threaded
- Socket Weld
- Flanged (welded)

Standard Materials

- Body/Spring Housing: 316L Stainless Steel
- Adjusting Screw: Nitronic 60
- Seat: Teflon – standard; Nylon, PEEK & Delrin – optional
- Orifice: 316L Stainless Steel
- Piston: Nitronic 60
- Cylinder: 316L Stainless Steel
- O-Rings: Buna-N (-65°F to 250°F/-54°C to 121°C); EPDM (-20°F to 450°F/-29°C to 232°C); Viton (15°F to 400°F/-26°C to 204°C)
- Trim Bushings & Seats: Teflon
- Shutoff: Class VI
- For other body/trim materials, please consult factory

ORDERING SCHEMATIC

MODEL	
5800HP	Standard

BODY MATERIAL	
316	316 Stainless Steel

O-RING	
B	Buna-N
E	EPDM
V	Viton

1 & 2		BODY	
Size	End Connection		
A	1/2" (DN15)	A	FNPT
B	3/4" (DN20)	B	FSW
C	1" (DN25)	C	150# Flange
		D	300# Flange
		E	600# Flange
		F	900# Flange
		G	1500# Flange
ZZ	Non-Standard		

Body Pressure/Temperature

- 2500 psig @ 100°F (172 bar @ 38°C)
- 2500 psig @ 450°F (172 bar @ 232°C)

Standard Cv: 1.0 (0,9 Kv)

Standard Range: 400 - 2500 psi (27,5 - 172 bar); for lower setpoints, contact factory

Weight: 10 lbs (4,5 kgs)

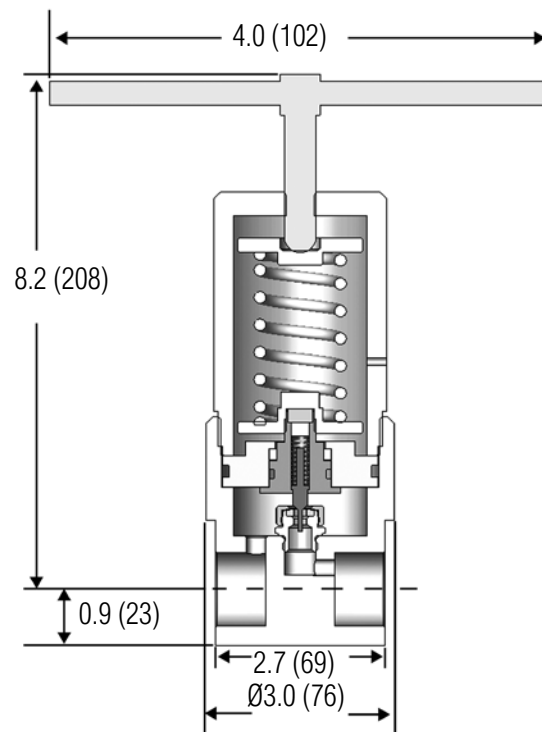
DIMENSIONS

3 & 4		TRIM
EE		Cv 1.0 316 / TFE
ZZ		Non-Standard

5 & 6		SET RANGE
R4		240 - 800 psi (17 - 55 bar)
R9		400 - 2500 psi (27,5 - 172 bar)
ZZ		Non-Standard

7 & 8		ACCESSORY
SC		Clean / Oil Free
ZZ		Non-Standard