



Mark 15 Series

Top Mounted Pneumatic Valve Positioners

TOP MOUNTED PNEUMATIC VALVE POSITIONERS

The Mark 15 positioner uses the full force of its air supply to drive and maintain a pneumatic actuator to position a valve to what is required by control instrument, regardless of the presence of forces that change valve position.

This line of compact instruments incorporates a single-axis, force-balance principle of operation to ensure accurate and stable control valve positioning. In all cases, including bottom-loading applications, a MK15 is mounted directly on the topworks of the valve, with no external levers or other exposed mechanisms.

Each positioner receives a signal from a control instrument, and using an air supply as high as 50 psig (3,4 bar), the positioner strokes the valve actuator to the required position.

Like all valve positioners, the MK15 has feedback circuits designed to measure the position of the actuator's piston or diaphragm. The positioner then supplies or exhausts air to bring the actuator within the required range for its corresponding control instrument.

The position of the valve actuator is sensed by the amount of compressive force exerted by a spring on the valve positioner's diaphragm assembly. By selecting the appropriate spring from the wide selection available almost any combination of valve stroke (from 1/4" to 4"; 6,4mm to 102mm) and instrument spans of 6,12, and 24 psi (0,4, 0,8 and 1,7 bar) can be obtained.

Features:

- Single-axis, force-balance principle of operation, ensures accurate and stable positioning
- Feedback circuits direct the actuator's position, ensuring adherence to the control instrument signal
- Accommodates a wide variety of valve strokes and instrument spans
- Can be direct-mounted to top of pneumatic actuator
- Offers a smaller, more streamlined package with no external linkage



A Division of
Richards Industrials
3170 Wasson Road
Cincinnati, OH 45209

513.533.5600
lowflow@richardsind.com

www.lowflowvalve.com

MARK 15 SERIES

Input: 3-15, 6-30, 3-9 or 9-15 psi (0,2-1,0; 0,4-2,1; 0,2-0,6; or 0,6-1,0 bar)

Air Supply Pressure:

- 35 – 45 psi reverse acting 3-9 / 9-15 / 3-15 / 6-30 ranges
- 20 – 25 psi direct acting 3-9 / 9-15 / 3-15 ranges
- 35 – 45 psi direct acting 6-30

Output: 0-100% supply pressure

Operating Temperature Limits: -40°F to +180°F (-40°C to + 82°C)

Air Consumption (@20 psi): 0.25 scfm; (@ 1,4 bar: 0.0007N/m3)

Flow Capacity: 4.4 scfm (0.125N/m3) (for 3-15 psi output pressure change) (0,2-1,0 bar)

Repeatability: 1/2% of full stroke

Sensitivity: responds to control air pressure changes as small as 0.1% of full range

Connections: 1/4" FNPT

Dimensions: 4.65" H x 3.5" Diameter (117,6mm x 88,9mm); external dimensions when mounted

Net Weight: 2-1/2 pounds (1,1 Kg)

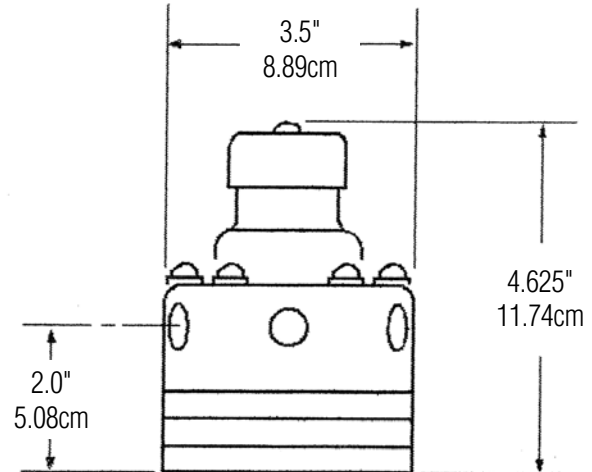

The topworks of the valve must have six, 1/4-20 x 9/16 deep holes (minimum) blind tapped, equally spaced on a 03,000 B.C. for mounting positioners.