



- Fractional Flow Control Valves
- Heavy Duty Control Valves (DN8 - DN50)
- Pressure Regulators
- Back Pressure Regulators
- Piston Operated Pressure Regulators
- Diaphragm-Sensed Pressure Regulators
- High Pressure Regulators (up to 827 bar/12,000 psi) inlets

 **LOWFLOW**
PRODUCT CATALOG



ABOUT US

LowFlow control valves and regulators are often used in OEM, laboratory or pilot plant applications. Installations such as these frequently require valve trim changes in order to meet varying flow requirements for a given application.

We understand the value in manufacturing a product designed with this flexibility in mind. That is why all LowFlow control valves offer a multitude of Kv's and flow characteristics in every line size.

Our control valves require no special tools for trim changes, and our bolted body design means you don't even have to take the valve out of line for trim changes or maintenance.

At LowFlow Valve, we've broadened the idea of what "typical" means. While some manufacturers fill a niche with their products, we've proven our mettle across an incredibly diverse range of industries and applications. LowFlow is successfully operated in cryogenic applications down to -254°C (-425°F) to temperatures above 538°C (1000°F).

We control steam, gases, liquids and even VOC's with our bellows design. We realize application challenges are not limited to just temperature or utilities. At LowFlow, Monel, Hastelloy, Alloy 20, Titanium, Kynar and Inconel are just a few of the materials we offer to address your material compatibility challenges.

LOWFLOW VALVE
3170 Wasson Road
Cincinnati, OH 45209
USA

+1.513.533.5600
LowFlowValve.com
LowFlow@Richardsind.com

TABLE OF CONTENTS

DESCRIPTION	PAGES
FRACTIONAL FLOW CONTROL VALVES	5-18
HEAVY DUTY CONTROL VALVES	19-23
PRESSURE REGULATORS	24-38
JORLON DIAPHRAGM	26-17
BACK PRESSURE REGULATORS	39-43

FOR **CRITICAL** CONTROL
OF **LIQUID, GAS** OR
STEAM FLOW...

WE ARE YOUR
TRUSTED, HIGH
PERFORMANCE
SOLUTION



Look for the LowFlow Express symbol for next day shipments

FRACTIONAL FLOW CONTROL VALVES



MARK 708 SERIES

When Precision Matters

When you need to specify a control valve, a broad range of options is important, and sometimes, critical. At LowFlow Valve, we have the solutions you need.

MATERIALS

- Carbon Steel (Nace Certified Variant)
- Stainless Steel (Nace Certified Variant)
- Alloy 20
- Hastelloy B
- Hastelloy C
- Titanium
- Monel
- Other materials upon request

ACTUATORS

- Pneumatic
- Electric

KV'S (CV'S)

- 0,000009 to 3,4 (0.00001 to 4)

LINE SIZES

- DN8 to DN20 (1/4" to 3/4")

PRESSURES

- Up to 827 bar (12000 psi inlet)

ACTUATOR SIZES

- 7M
- 14M
- 35M



ACCESSORIES/REGULATORS

- Siemens PS2 - standard side positioner
- Eckardt SRP981 - side mount positioner
- Westlock ICOT 5000 - side mount positioner
- Moore 73-N12-F - top mount positioner
- MAC 225B-111CA - solenoid valve
- Bellofram 51FR - air filter regulator
- 4" Handwheel - handwheel for manual override
- Limit switches - limit switches
- MK10 Series - pressure controller
- Manual handles - manual control handles
- Paint - paint options
- Locking features - regulator locking options

* others upon request

GENERAL APPLICATIONS

- Pilot plants
- OEM's
- Dosing and injection units
- Steam/process services
- Chemical dosing
- Venting
- Cryogenics
- Oxygen and hydrogen control
- Additive injection
- Hazardous liquids
- High pressure control
- Laboratory processes
- Fuel control
- Biopharm skids

END CONNECTIONS

MK708 Series

End Connections

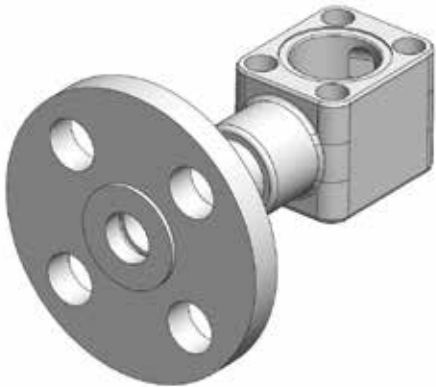

ANSI / DIN FLANGE

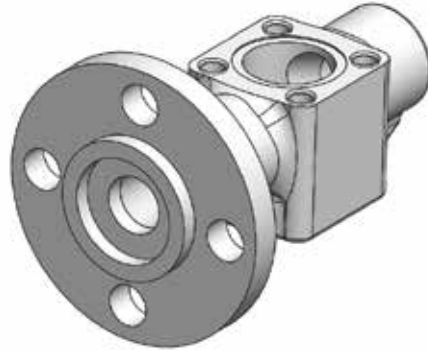

JIS 10K/20K FLANGE

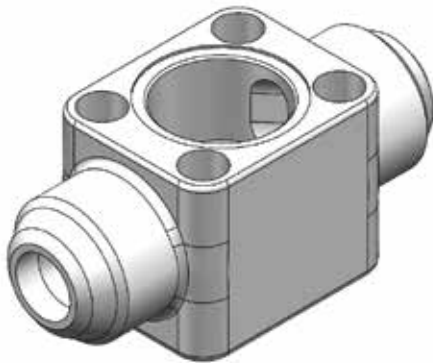

BUTT WELD

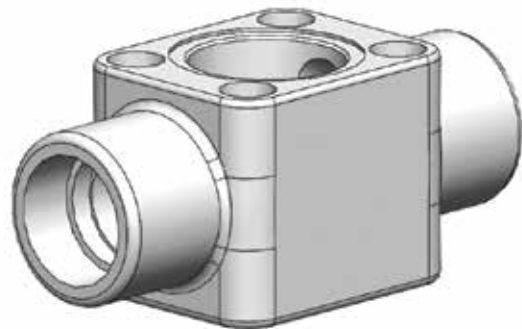

SOCKET WELD & NPT (THREADS NOT SHOWN)

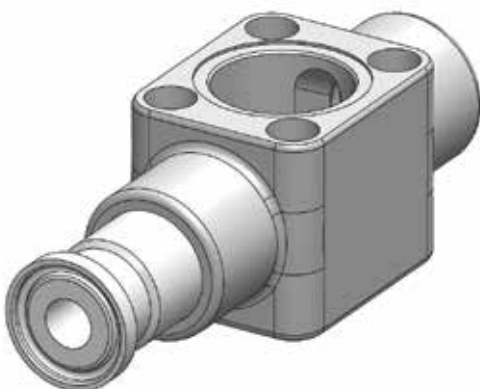

TRI-CLAMP

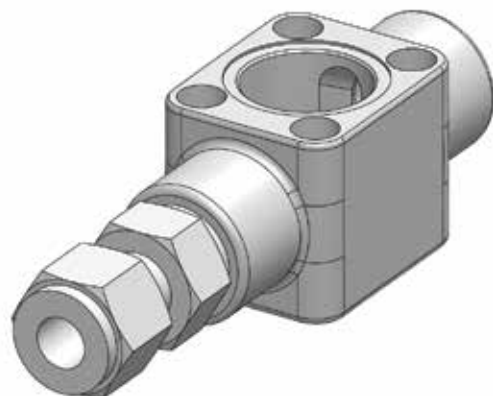

SWAGELOK

Grayloc and custom ends also available

MARK 708 SERIES

Precise Control

DESCRIPTION & APPLICATION

The Mark 708 was developed by LowFlow Valve to provide accurate control on fractional flow applications. It is a complete line of pneumatic and electrically actuated control valves designed to enhance performance to ensure precision control on your most critical micro flow applications.

- Pilot plant installations
- Test standards
- R & D facilities
- Processing plants
- Specialized processing plants (dosing, injection and venting)

INDUSTRIES

- Aviation & aerospace
- Chemical, refining & petrochemical
- Oil & gas
- Process or industrial
- Test equipment & services

QUICK SPECIFICATIONS

Seat Type	Globe - Class IV or VI
Sizes	DN8 - DN20 (1/4" - 3/4")
End Connections	Threaded, Socket Weld, Integral Tube, Welded Flange
Body Materials	Carbon Steel, Stainless Steel, Hastelloy C, Monel, Alloy 20, others
Kv (Cv)	0,000009 to 3,4 (0.00001 to 4.0)
Ranges	0,207- 1,03 or 0,41 - 2,07 bar (3-15 or 6-30 psi); split ranges are available with optional positioner



KEY FEATURES

- Rolling diaphragm
- Spring-loaded TFE/Chevron packing
- Bolted body/bonnet connection
- Guided trim standard
- Quick change trim standard (0,04 Kv / 0.05 Cv and above)
- Threaded bonnet for quick disassembly
- Secondary stem connection eliminates stroke adjustment when changing trim
- Optional side mounted or top mounted positioner

MARK 708BS SERIES

Bellows Stem Seal

DESCRIPTION & APPLICATION

Bellows stem seals eliminate fugitive emissions by surrounding the valve stem with a pressure-tight barrier, isolating the stem from the process fluid and preventing leakage to the atmosphere. For an extra measure of protection, the bellows stem seal option provides a back-up seal of Teflon or Graphite/Grafoil packing along with a threaded or NPT detection port for use in monitoring potential emissions leakage.

- Pilot plant installations
- Test standards
- R & D facilities
- Processing plants
- Fugitive emissions
- Hazardous service

INDUSTRIES

- Aviation & aerospace
- Chemical, refining & petrochemical
- Oil & gas
- Process or industrial
- Test equipment & services



QUICK SPECIFICATIONS

Seat Type	Globe - Class IV or VI
Sizes	DN8 - DN20 (1/4" - 3/4")
End Connections	Threaded, Socket Weld, Integral Tube, Welded Flange
Body Materials	Carbon Steel, Stainless Steel, Hastelloy C, Monel, Alloy 20, others
Kv (Cv)	0,000009 to 3,4 (0.00001 to 4.0)
Ranges	0,207- 1,03 or 0,41 - 2,07 bar (3-15 or 6-30 psi); split ranges are available with optional positioner

KEY FEATURES

- Rolling diaphragm
- Standard bonnet port for use in lubricating the packing for added protection against leakage or for use as a detection port for monitoring potential fugitive emissions
- Tri-ply bellows provides added strength and enhanced performance
- Interchangeable trim sets
- Threaded bonnet for easy removal of the bellows assembly
- Bolted body/bonnet connection
- Optional side mounted or top mounted positioner

Consult factory if outlet pressure is above 17 bar (250 psi)

MARK 708CR SERIES

Extended Bonnet

DESCRIPTION & APPLICATION

The Mark 708CR for cryogenic service features a 23 cm (9") bonnet extension (optional 35,5cm / 14") that provides protection for the packing and actuator by preventing ice build-up, which can interfere with movement of the valve stem and affect valve performance. For cryogenic services with temperatures as low as -254°C (-425°F).

- Pilot plant installations
- R & D facilities
- Liquid CO₂
- Hydrogen
- Nitrogen
- Low temperature applications

INDUSTRIES

- Aviation & aerospace
- Chemical, refining & petrochemical
- Oil & gas
- Process or industrial
- Test equipment & services

QUICK SPECIFICATIONS

Seat Type	Globe - Class IV
Sizes	DN8 - DN20 (1/4" - 3/4")
End Connections	Threaded, Socket Weld, Integral Tube, Welded Flange
Body Materials	Stainless Steel, Hastelloy C, Monel, Alloy 20, others
Kv (Cv)	0,04 to 3,4 (0.05 to 4.0)
Ranges	0,207- 1,03 or 0,41 - 2,07 bar (3-15 or 6-30 psi); split ranges are available with optional positioner



KEY FEATURES

- Protects the packing and actuator by preventing ice build-up which can interfere with stem movement
- Wide range of interchangeable trims
- TFE chevron ring packing
- Optional side mounted or top mounted positioner

CONTROL VALVES

MARK 708DP SERIES

Double Packing

DESCRIPTION & APPLICATION

An alternative to a bellows stem seal, it is used when standard packing will not adequately contain the controlled media. With a double packed bonnet, lubricant is pumped into the packing sets, providing a tight seal similar to bellows stem seal.

- Pilot plant installations
- Test stands
- R & D facilities
- Processing plants
- Specialized processing plants
- Government agencies
- Hazardous service

INDUSTRIES

- Chemical, refining & petrochemical
- Oil & gas
- Process or industrial
- Test equipment & services



QUICK SPECIFICATIONS

Seat Type	Globe - Class IV or VI
Sizes	DN8 - DN20 (1/4" - 3/4")
End Connections	Threaded, Socket Weld, Integral Tube Nuts, Welded Flange
Body Materials	Carbon Steel, Stainless Steel, Hastelloy C, Monel, Alloy 20, others
Kv (Cv)	0,000009 to 3,4 (0.00001 to 4.0)
Ranges	0,207- 1,03 or 0,41 - 2,07 bar (3-15 or 6-30 psi); split ranges are available with optional side-mounted positioner

KEY FEATURES

- Ideal for applications where service conditions can damage a bellows assembly
- Features standard bonnet port for use in lubricating the packing for added protection against leakage, or for use as a detection port for monitoring potential fugitive emissions
- Optional side mounted or top mounted positioner

MARK 708HP SERIES

High Pressure

DESCRIPTION & APPLICATION

An 8000 psi (552 bar) maximum inlet fractional flow control valve. This rugged, compact control valve is suitable for a variety of industrial and research applications. Linear and equal percentage flow characteristics are available with Kv's ranging from 0,04 (0.05 Cv) to 1,1 (1.25 Cv). In addition, it is available in a variety of end connections and optional materials of construction making it a versatile solution to your demanding valve requirements.

- Offshore chemical injection
- Hydrocarbon processing
- Chemical processing
- Other high pressure applications

INDUSTRIES

- Aviation & aerospace
- Chemical, refining & petrochemical
- Oil & gas
- Process or industrial
- Test equipment & service



QUICK SPECIFICATIONS

Seat Type	Globe - Class III or IV
Sizes	DN 15 (1/2")
End Connections	Threaded (FNPT), Autoclave, Socket Weld, Integral Tube, Welded Flange
Body Materials	Carbon Steel, Stainless Steel, Hastelloy C, Monel, Alloy 20, others
Kv (Cv)	0,04 to 1,1 (0.05 to 1.25)
Ranges	0,207- 1,03 or 0,41 - 2,07 bar (3-15 or 6-30 psi); split ranges are available with optional top-mounted positioner

KEY FEATURES

- Union style body/bonnet connection - provides solid construction and secure connection
- Mechanically loaded PTFE Chevron heavy duty V ring packing
- Rolling diaphragm
- Guided trim
- Standard with side mount positioner
- Optional top mounted positioner

MARK 708HPA SERIES

High Pressure Angle

DESCRIPTION & APPLICATION

An 827 bar (12,000 psi) maximum inlet fractional flow control valve. Linear and equal percentage flow characteristics are available with Kv's ranging from 0,04 (0.05 Cv) to 1,1 (1.25 Cv). The Mark 708HPA is available in a variety of end connections and optional materials of construction making it a versatile solution to your most demanding valve requirements.

- High pressure industrial
- Research applications
- Offshore well system chemical injection

INDUSTRIES

- Aviation & aerospace
- Chemical, refining & petrochemical
- Oil & gas
- Process or industrial
- Test equipment & services

QUICK SPECIFICATIONS

Seat Type	Globe - Class III or IV
Sizes	DN15 (1/2")
End Connections	Threaded (FNPT), Autoclave AE, Socket Weld, Integral Tube Nuts
Body Materials	Stainless Steel, Monel, Alloy 20
Kv (Cv)	0,04 to 1,1 (0.05 to 1.25)
Ranges	0,207- 1,03 or 0,41 - 2,07 bar (3-15 or 6-30 psi); split ranges are available with optional top-mounted positioner



KEY FEATURES

- Union style body/bonnet connection - provides solid construction and secure connection
- The metal 'C' ring gasket provides excellent sealing without exposing the bonnet threads to the media
- Mechanically loaded PTFE Chevron heavy duty V ring packing - the adjustable packing arrangement maintains a proper compression, while minimizing excessive friction
- Rolling diaphragm - ensure that the effective diaphragm area remains relatively constant, regardless of valve stem position
- Standard with side positioner

MARK 708HT SERIES

Finned Bonnet

DESCRIPTION & APPLICATION

The cooling fin bonnet option is for the protection of the stem packing from elevated temperatures associated with steam, hot water, and high temperature oil, gas and liquid services (up to 538°C; 1000°F). The finned bonnet cools the area around the packing, which permits the use of standard packing materials that otherwise would not be suitable for the service temperature conditions.

- Pilot plant installations
- Test stands
- R & D facilities
- Processing Plants
- Specialized processing plants

INDUSTRIES

- Aviation & aerospace
- Chemical, refining & petrochemical
- Oil & gas
- Process or industrial
- Test equipment & service

QUICK SPECIFICATIONS

Seat Type	Globe - Class IV
Sizes	DN8 - DN20 (1/4" - 3/4")
End Connections	Threaded, Socket Weld*, Integral Tube, Welded Flange* (*DN15 & 20; 1/2" & 3/4" only)
Body Materials	Carbon Steel, Stainless Steel, Hastelloy C, Monel, Alloy 20, others
Kv (Cv)	0,04 to 3,4 (0.05 to 4.0)
Ranges	0,207- 1,03 or 0,41 - 2,07 bar (3-15 or 6-30 psi); split ranges are available with optional top-mounted positioner



KEY FEATURES

- For steam, hot water, and high temperature oil, gas and liquid service
- Provides cooling effect on bonnet, protecting the packing from higher than normal temperature conditions
- For precise control of higher temperature fractional flow services in pilot plant process applications

CONTROL VALVES

MARK 708ME SERIES

Motor Valve

DESCRIPTION & APPLICATION

The Mark 708ME offers many advantages including extreme accuracy, high turndown ratios and repeatability. The features of this high resolution, low hysteresis digitally controlled motor valve makes the MK708ME a premier control valve for many applications.

- Chemical injection
- Dosing
- Pilot plants
- Research labs
- Skid builders

INDUSTRIES

- Aviation & aerospace
- Chemical, refining & petrochemical
- Oil & gas
- Process or industrial
- Test equipment & services

QUICK SPECIFICATIONS

Seat Type	Globe - Class IV or VI
Sizes	DN8 - DN20 (1/4" - 3/4")
End Connections	Threaded, Socket Weld, Integral Tube, Welded Flanged
Body Materials	Carbon Steel, Stainless Steel, Hastelloy C, Monel, Alloy 20, others
Kv (Cv)	0,000009 to 3,4 (0.00001 to 4.0)
Ranges	Current voltage command, on/off



KEY FEATURES

- Spring-loaded TFE/Chevron packing
- Bolted body/bonnet connection
- Guided trim
- Manual operation by stowable hand crank
- Output shaft with soft seating mechanism

MARK 708MV SERIES

Motor Valve

DESCRIPTION & APPLICATION

The Mark 708MV offers several advantages including extreme accuracy, high turndown ratios and repeatability. The MK708MV includes a switch-selectable power supply, a hand drive mechanism for manual operation, and a 4-20mA current input signal. Upon loss of input (not loss of power), the motor is designed to either lock in place, or fail to minimum input signal position.

- Chemical injection
- Dosing
- Pilot plants
- Research labs
- Skid builders

INDUSTRIES

- Aviation & aerospace
- Chemical, refining & petrochemical
- Oil & gas
- Process or industrial
- Test equipment & service

QUICK SPECIFICATIONS

Seat Type	Globe - Class IV or VI
Sizes	DN8 - DN20 (1/4" - 3/4")
End Connections	Threaded, Socket Weld, Integral Tube Ends, Welded Flanges
Body Materials	Carbon Steel, Stainless Steel, Hastelloy C, Monel, Alloy 20, others
Kv (Cv)	0,000009 to 3,4 (0.00001 to 4.0)
Ranges	Current voltage command, on/off



KEY FEATURES

- Manual operation by hand knob
- Output shaft with soft seating mechanism
- 4-20mA position feedback possible with standard motor
- No external power source is needed for feedback
- Unrestricted modulating duty
- Spring-loaded TFE/Chevron packing
- Bolted body/bonnet connection
- Guided trim

CONTROL VALVES

MARK 709 SERIES

Three Way

DESCRIPTION & APPLICATION

The Mark 709 is a lightweight control valve for use as a mixing valve in low flow process applications. Featuring a three-way body design, it is constructed with two inlets to blend two separate flow streams into a common outlet, creating a third fluid.

- Mixing
- Bypass
- Chemical injection
- Dosing
- Pilot plants
- Research labs

INDUSTRIES

- Aviation & aerospace
- Chemical, refining & petrochemical
- Oil & gas
- Process or industrial
- Test equipment & services

QUICK SPECIFICATIONS

Seat Type	Globe - Class IV or VI
Sizes	DN15 & DN20 (1/2" & 3/4")
End Connections	Threaded, Socket Weld, Integral Tube, Welded Flange
Body Materials	Carbon Steel, Stainless Steel, Hastelloy C, Monel, Alloy 20, others
(Kv (Cv))	1,1 to 3,4 (1.25 to 4.0)
Ranges	0,207- 1,03 or 0,41 - 2,07 bar (3-15 or 6-30 psi); split ranges are available with optional top-mounted positioner



KEY FEATURES

- For low flow process applications requiring a three way body for mixing two separate flow sources into one common line
- Compact, lightweight design for precise control
- Multiple spring actuators in a choice of sizes for differential pressures up to 100 bar (1460 psi)

HEAVY DUTY CONTROL VALVES

The MK8000 Series is our line of heavy-duty control valves designed for process applications requiring full or fractional flow. The MK8000 series is available in line sizes (DN15 - DN50 (1/2" - 2")), with KVs ranging from 0,04 to 14,5 (CV's ranging from 0.05 to 17), and can operate in temperatures as low as -254°C (-425°F). The MK8000 is manufactured in multiple configurations to suit your application, be it with a cryogenic bonnet for low temperature applications, with a T configuration for mixing, or a Bellow Stem Seal for hazardous/lethal service.

The MK8000 Series valve sub-assembly is manufactured completely from barstock, providing flexibility for the materials of construction. The MK8000 Series is routinely manufactured in exotic alloys such as Alloy 20, Hastelloy, Monel, Inconel, Zirconium, Titanium, as well as in plastics, such as Kynar, PVC, and CPVC.

CONTROL VALVES

MARK 8000 SERIES

Heavy Duty

DESCRIPTION & APPLICATION

The Mark 8000 Series is a group of heavy duty control valves specifically designed for process applications requiring full flow or fractional flow control. Available with a wide selection of body sizes and styles, this valve can be configured in 2-way or 3-way designs, for diverting or mixing service, and with globe or angle valve style seats.

- Corrosive or harsh process environments
- Test stands
- R & D facilities
- Processing plants
- Specializing processing plants (dosing, injection and venting)

INDUSTRIES

- Aviation & aerospace
- Chemical, refining & petrochemical
- Oil & gas
- Process or industrial
- Test equipment & services

QUICK SPECIFICATIONS

Seat Type	Globe or Angle - Class III, IV or VI
Sizes	DN15 - DN50 (1/2" - 2")
End Connections	NPT, BSPT, Raised-face Flanges (ANSI, DIN, JIS), Ring Type Joint Flanges, Socket Weld, Bolt-thru Flanged
Body Materials	Carbon, Steel, Stainless Steel, Brass, Monel, Hastelloy C, Alloy 20, Stellite, Kynar, PVC
Kv (Cv)	0,04 to 14,5 (0.05 to 17)
Ranges	0,207- 1,03 or 0,41 - 2,07 bar (3-15 or 6-30 psi); split ranges are available with optional positioner



KEY FEATURES

- Totally enclosed multi-spring actuator which minimizes deadband and is field reversible
- Wide range of positioners and actuators
- Heavy-duty barstock construction for pressures up to 414 bar (6000 psi)
- Available in Kynar, PVC and CPVC
- Specialty alloys are readily available
- In-line design to DN50 (2"); angle pattern up to DN25 (1")
- In-line maintainable for quick, easy trim repairs

MARK 800BS SERIES

Bellows Stem Seal

DESCRIPTION & APPLICATION

Bellows stem seals eliminate fugitive emissions by surrounding the valve stem with a pressure-tight barrier, isolating the stem from the process fluid and preventing leakage to the atmosphere. For an extra measure of protection, the bellows stem seal option provides a back-up seal of Teflon, braided or Graphite/Grafoil packing.

- Pilot plant installations
- Test stands
- R & D facilities
- Processing plants
- Hazardous service
- Fugitive emissions

INDUSTRIES

- Aviation & aerospace
- Chemical, refining & petrochemical
- Oil & gas
- Process or industrial
- Test equipment & services



QUICK SPECIFICATIONS

Seat Type	Globe or Angle - Class III, IV or VI
Sizes	DN15 - DN32 (1/2" - 1-1/4")
End Connections	NPT, BSPT, Raised-face Flanges (ANSI, DIN, JIS), Ring Type Joint Flanges, Socket Weld, Bolt-thru Flanged
Body Materials	Carbon Steel, Stainless Steel, Brass, Monel, Hastelloy B & C, Alloy 20, Kynar, PVC
Kv (Cv)	0,04 to 6,2 (0.05 to 7.1)
Ranges	0,207- 1,03 or 0,41 - 2,07 bar (3-15 or 6-30 psi); split ranges are available with optional positioner

KEY FEATURES

- Barstock, not cast, construction to avoid potential porosity issues
- Available in Kynar, PVC and CPVC
- Full compliance with most stringent requirements of the Clean Air Act
- Secondary packing chamber with a bellows leak monitoring port for additional security
- Two-piece stem allows stem adjustment without breaking the bellows bonnet extension seal

MARK 8000CR SERIES

Cryogenic Option

DESCRIPTION & APPLICATION

The extended option offers an 8" bonnet extension that provides protection for the packing and actuator by preventing the formation and build-up of ice, which can interfere with movement of the valve stem and affect valve performance and control. This model is for use on cryogenic service with temperatures as low as -254°C (-425°F).

- Cryogenic
- Liquefied gases
- Liquid CO₂
- Hydrogen
- Nitrogen
- Low temperature applications

INDUSTRIES

- Aviation & aerospace
- Chemical, refining & petrochemical
- Oil & gas
- Process or industrial
- Test equipment & services

QUICK SPECIFICATIONS

Seat Type	Globe - Class III or IV
Sizes	DN15 - DN50 (1/2" - 2")
End Connections	NPT, BSPT, Raised-face Flanges (ANSI, DIN, JIS), Ring Type Joint Flanges, Socket Weld, Bolt-thru Flanged
Body Materials	Carbon Steel, Stainless Steel, Brass, Monel, Hastelloy C, Alloy 20, Stellite
Kv (Cv)	0,043 to 14,6 (0.05 to 17)
Ranges	0,207- 1,03 or 0,41 - 2,07 bar (3-15 or 6-30 psi); split ranges are available with optional positioner



KEY FEATURES

- Extended bonnet protects the packing and actuator by preventing ice build-up, which can interfere with stem movement and/or damage packing
- For services as low as -254°C (-425°F)
- Barstock construction eliminates possible porosity concerns

MARK 8000T SERIES

Three-Way

DESCRIPTION & APPLICATION

The three-way 8000T can be specified for use on mixing or diverting services. As a mixing valve, it is designed with two inlets to blend two separate flow streams into a common outlet creating a third fluid. For diverting service, the valve features one inlet and two outlets, allowing you to divert the flow from one outlet to the other as required to bypass heat exchangers, coolers filters, or other pieces of process equipment.

- Diverting service
- Mixing service

INDUSTRIES

- Aviation & aerospace
- Chemical, refining & petrochemical
- Oil & gas
- Process or industrial
- Test equipment & services

QUICK SPECIFICATIONS

Seat Type	Globe - Class III, IV or VI
Sizes	DN15 - DN25 (1/2" - 1")
End Connections	Threaded, Socket Weld, Flanged
Body Materials	Carbon Steel, Stainless Steel, Brass, Hastelloy, others
Kv (Cv)	0,17 to 5,1 (0.2 to 6.0)
Ranges	0,207- 1,03 or 0,41 - 2,07 bar (3-15 or 6-30 psi); split ranges are available with optional positioner



KEY FEATURES

- Mixing two separate flow sources into one common line; diverging a single flow path into two separate streams, or used as a bypass to divert flow from one outlet to another
- For three way industrial process applications requiring durable construction and precision control of standard or low flows
- Field reversible without the use of special tools or extra parts

PRESSURE & BACK PRESSURE REGULATING VALVES



LOWFLOW VALVE CATALOG



The LowFlow J-Series is our line of high pressure regulators used for handling high pressure and low flow applications. The J-Series line consists of pressure reducing valves (PRVs), back pressure reducing valves (BPRVs), and Dome Loaded valves. These products are typically used in research and sampling systems for general, corrosive and specialty gas, and liquid service. The J-Series spans line sizes from DN8 - DN20 (1/4" - 3/4"). The J-Series can handle inlet pressures up to 630 bar (9,135 psi) and offers both piston sensed regulation for high pressure applications, as well as diaphragm sensing for low pressure/high sensitivity applications.

COMMON APPLICATIONS

- Gas compression
- Gas chromatography
- Natural gas treatment systems
- Test benches
- Conductivity analyzers
- Gas analyzers
- Sparging
- Tank blanketing

JORLON DIAPHRAGM

WHAT IS JORLON™?

Jorlon™ is structurally modified pure PTFE. It is manufactured by a proprietary technique where PTFE layers are combined and formed in a unique process to reduce the creep and cold flow associated with conventionally formed solid, or laminated PTFE or Teflon.

LowFlow Valve warrants the Jorlon™ diaphragm on the:

- JR Series
- JB Series
- JRH Series
- JRHF Series
- JRL Series
- JRHL Series



for a lifetime of use on all clean utility or process applications at continuous operating pressures, temperature and conditions as specified in each model's data sheet

Physical Properties of Jorlon

Color	Clear, translucent	
Composition	PTFE	
Temperature	Min/Max	Min -212°C (-350°F) to Max 260°C (500°F)
Creep relaxation (ASTM F38)	%	35
Specific Gravity (D792)	2.19	
Compressibility (ASTM F36)	% Range	20 - 25
Recovery (ASTM F36)	Min. %	50
Tensile Strength (ASTM D1708)		
X Direction	psi (N/mm ²)	5000 (35)
Y Direction	psi (N/mm ²)	5100 (36)
Ultimate Elongation (ASTM D1708)		
X Direction	%	500
Y Direction	%	520
Gas Permeability (ASTM D1434V)	Cc/M ² /24 hrs	10,000
Flammability	Will not burn	

Jorlon™ Material

Jorlon™ has been used by LowFlow for over 9 years. To date, not one valve has been returned due to diaphragm failure when operating within its use parameters. Jorlon has been nitrogen pressure tested to over 83 bar (1200 psi) without failure.



Product Applications

Jorlon has extremely long life cycles. It provides superior accuracy, while maintaining excellent pressure/temperature and chemical capabilities

Improved Performance

Stainless Steel diaphragms are rigid by nature, thus have decreased sensitivity. The Jorlon material approaches the droop performance seen in true elastomer diaphragms resulting in greater set point accuracy

Cycle Testing

Jorlon™ has been tested on a variety of LowFlow regulators on 3 bar (45 psig) continuous steam service to over 1 million full stroke cycles.

Lab Testing

Lab tests comparing Jorlon™ to 316L diaphragms have shown continued life after exceeding the SST failure cycle count by more than 100 times

PRESSURE REGULATING VALVES

J SERIES

Quick Specification

Series	Type	Size Range	Kv (Cv)
JB	High pressure BPRV	DN8, DN10, DN15	0,04 - 0,30 (0.05, - 0.35)
JBDL	Medium pressure BPRV	DN15	1,69 (1.95)
JBPH	Piston-sensed high pressure BPRV	DN15, DN20, DN25	0,43 (0.5)
JR	High pressure PRV	DN8, DN10, DN15	0,01 - 0,17 (0.012 - 0.20)
JRDL	Diaphragm operated PRV	DN15, DN20, DN25	1,46 (1.7)
JRH	High pressure PRV	DN10 & DN15	0,69 (0.08)
JRHF	Low pressure PRV	DN15, DN20, DN25	1/2": 1,3 (1.5); 3/4" - 1": 1,6 (1.9)
JRHL	Low pressure PRV	DN15 & DN20	0,7 (0.8) & 0,43 (0.)
JRLL	Low pressure PRV	DN8, DN10, DN15	0,01 - 0,17 (0.012 - 0.20)
JRPH/JRPL (DN8)	Piston-sensed high pressure PRV	DN8	0,01, - 0,17 (0.012- 0.2)
JRPH/JRPL	Piston-sensed high pressure PRV	DN15, DN20, DN25	1,8 (2.1)
5800	Piston-sensed high pressure BPRV	DN15, DN20, DN25	0,9 (1.0)
5850	Piston-sensed high pressure BPRV	DN15	0,34 (0.4)
6800	Piston-sensed high pressure PRV	DN15, DN20, DN25	0,4; 0,86; 2,1 (0.5, 1.0, 2.5)

Series	Setpoints	Shutoff Class	Feature/Option
JB	up to 52 bar (9,135 psi)	Class VI	Panel mount & captured vents options
JBDL	up to 28 bar (400 psi)	Class VI	High flow with inlet pressures to 83 bar
JBPH	up to 400 bar (5800 psi)	Class VI	Inlet pressure to 414 bar (6000 psi)
JR	up to 52 bar (750 psi)	Class VI	Jorlon diaphragm
JRDL	up to 28 bar (400 psi)	Class VI	Very high pressures and very low flows.
JRH	0,14 - 0,69 bar (2 - 10 psi) to 5,2 - 31 bar (75 - 450 psi)	Class VI	Barstock design
JRHF	up to 10 bar (150 psi)	Class VI	Inline removable seat
JRHL	up to 3,45 bar (50 psi)	Class VI	Large diaphragm, increased stability at low setpoints
JRLL	0,7 - 5,2 bar (1 - 75 psi) and 1,7 - 6,9 bar (25 - 100 psi)	Class VI	Large diaphragm, increased stability at low setpoints
JRPH/JRPL (1/4")	up to 630 bar (9135 psi)	Class VI	Inlet pressures to 689 bar (10000 psi)
JRPH/JRPL	up to 400 bar (5800 psi)	Class VI	Piston sensing for better regulation at higher pressures
5800	27,6 - 345 bar (400 - 5000 psi)	Class VI	High flow in a compact design
5850	55 - 345 bar (800 - 5000 psi)	Class VI	High flow in a compact design
6800	17,2 - 207 bar (250 - 3000 psi)	Class III, IV, V, VI	Barstock construction

JR SERIES

High Pressure / Low Flows

DESCRIPTION & APPLICATION

The LowFlow JR Series line of high pressure regulators have the ability to handle very high pressures and very low flows. USDA and FDA approved soft goods available upon request.

- Research and sampling systems
- General, corrosive and specialty gas and liquid services (non-cavitating)

INDUSTRIES

- Research & sampling systems
- General, corrosive & specialty gas and liquid service
- Gas chromatography
- Flame ionization detectors
- Industrial controls

QUICK SPECIFICATIONS

Seat Type	PTFE, PEEK, KEL-F
Sizes	DN8, DN10, DN15 (1/4", 3/8", 1/2")
End Connections	Threaded, Socket Weld, Flanged, Others
Body Materials	316L Stainless Steel, Hastelloy C, Monel, Alloy 20, others
Kv (Cv)	0,01, 0,026, 0,07, 0,17 (0.012, 0.03, 0.08, 0.20)
Spring Range	up to 52 bar (750 psi)



KEY FEATURES

- Top entry design facilitates in-line cleaning and maintenance
- Barstock construction guarantees material integrity and surface finish
- High flow rate coupled with high rangeability reduces need for reduced trim sizes
- Optimized internal volume
- Jorlon diaphragm material provides exceptionally long life
- Soft seat material for ANSI Class VI shutoff

PRESSURE REGULATING VALVES

JRDL Series

Diaphragm Operated

DESCRIPTION & APPLICATION

The LowFlow JRDL Series line of diaphragm sensed, high pressure regulators have the ability to handle very high pressures and very low flows. USDA and FDA approved soft goods available upon request.

- High pressure gas
- Liquid pump systems control
- Water seal regulation
- Hyperbaric chambers
- Air compressors
- Pressurized ballast tanks
- Gas transfer systems
- Gas chromatography
- Flame ionization

INDUSTRIES

- Research and development
- Gas cabinets
- High pressure gas systems
- Injection molding



QUICK SPECIFICATIONS

Seat Type	Buna-N, EPDM, Viton
Sizes	DN15, DN20, DN25 (1/2", 3/4", 1")
End Connections	Threaded, Socket Weld, Flanged, Others
Body Materials	316L Stainless Steel, Hastelloy C, Monel, Alloy 20, others
Kv (Cv)	1,46 (1.7)
Spring Range	0,0 - 3,4 bar (0 - 50 psi); 0 - 6,9 bar (0 - 100 psi); 0 - 13,8 bar (0 - 200 psi); 0 - 28 bar (0 - 400 psi)

KEY FEATURES

- Ability to reduce high inlet pressures from 0 to 27,6 bar (1 to 400 psig) in one valve
- Provides superior sensitivity in pressure regulation to the piston operated JRPL, and has a Cv that's nearly 10x greater than the 0.2 Cv in the JR Series
- Barstock construction guarantees material integrity and surface finish
- High flow rate coupled with high rangeability reduces need for reduced trim sizes
- Optimized internal volume
- Soft seat material for ANSI Class VI shutoff

JRH SERIES

Very High Pressure / Low Flow

DESCRIPTION & APPLICATION

The LowFlow JRH Series of high pressure regulators has the ability to handle high pressures as well as low flows. USDA and FDA approved soft goods available upon request.

- Research and sampling systems
- General, corrosive and specialty gas and liquid services

INDUSTRIES

- Gas chromatography
- Flame ionization detectors
- Industrial controls



QUICK SPECIFICATIONS

Seat Type	KEL-F / Viton
Sizes	DN10 & DN15 (3/8" & 1/2")
End Connections	Threaded, Socket Weld, Flanged, Others
Body Materials	316L Stainless Steel, Hastelloy C, Monel, Alloy 20, others
Kv (Cv)	0,69 (0.08)
Spring Range	0,14 - 0,69 bar (2 - 10 psi) to 5,2 - 31 bar (75 - 450 psi)

KEY FEATURES

- Top entry design facilitates in-line cleaning and maintenance
- Barstock construction guarantees material integrity and surface finish
- High flow rate coupled with high rangeability reduces need for reduced trim sizes
- Optimized internal volume
- Jorlon diaphragm material provides exceptionally long life
- KEL-F soft seat material for ANSI Class VI shutoff

PRESSURE REGULATING VALVES

JRHF SERIES

High Flows

DESCRIPTION & APPLICATION

The JRHF Series is a diaphragm operated, balanced trim pressure regulator. The choice between 1,3 and 1,6 Kv (1.5 and 1.9 Cv) offers increased flows across the JRHF's 15,8 bar (230 psi) inlet range, while the PTFE soft seat provides ANSI Class VI shutoff. Four set spring ranges and three soft seal options offer the customer flexibility in a number of applications and environments. These valves are designed to regulate a variety of gases and liquids in applications where high flows and low control pressures are required. USDA and FDA approved soft goods available upon request.

- Gas and liquid applications where high flows and low control pressures are required

INDUSTRIES

- Research and development
- Gas cabinets
- High pressure gas systems
- Injection molding

QUICK SPECIFICATIONS

Seat Type	PTFE, PEEK
Sizes	DN15, DN20, DN25 (1/2", 3/4", 1")
End Connections	Threaded, Socket Weld, Flanged, Others
Body Materials	316L Stainless Steel, Hastelloy C, Monel, Alloy 20, others
Kv (Cv)	1/2": 1,3 (1.5) 3/4" - 1": 1,6 (1.9)
Spring Range	up to 10 bar (150 psi)



KEY FEATURES

- Top entry design facilitates in-line cleaning and maintenance
- Barstock construction guarantees material integrity and quality surface finish
- Balanced trim offers high flows with minimal lockup
- Optimized internal volume
- Jorlon diaphragm material provides exceptionally long life
- PTFE or PEEK soft seat for ANSI Class VI shutoff

JRHL SERIES

Low Set Pressure / Very Low Flows

DESCRIPTION & APPLICATION

The LowFlow JRHL Series is a line of low flow pressure regulators that have the ability to handle low set pressures and very low flows with less offset than valves with small diaphragms. The durable valve body and metal trim components are machined from 316L SST barstock. The valve is outfitted with the rugged Jorlon diaphragm and Teflon, PEEK or EPDM seats for ANSI Class VI shut-off. USDA and FDA approved soft goods available upon request.

- Continuous clean stem
- Non-cavitating liquids
- Sparging
- Tank blanketing

INDUSTRIES

- Production facilities and equipment which require gas flow regulation



QUICK SPECIFICATIONS

Seat Type	PTFE, PEEK, EPDM
Sizes	DN15 & DN20 (1/2" & 3/4")
End Connections	Threaded, Socket Weld, Flanged, Others
Body Materials	ASTM A479 316L SST, others
Kv (Cv)	0,43 (0.5) & 0,7 (0.8)
Spring Range	up to 3,45 bar (50 psi)

KEY FEATURES

- In-line removable seat and trim facilitates in-line cleaning and maintenance
- Barstock construction guarantees material integrity and quality surface finish
- Two Kv offerings of 0,7 (0.8 Cv) and 0,43 (0.5 Cv) and four spring ranges guarantees a valve that will fit your application
- Optimized internal volume
- Proprietary Jorlon diaphragm material provides exceptionally long life
- Soft seat material for ANSI Class VI shutoff

PRESSURE REGULATING VALVES

JRLL SERIES

Low Set Pressure / Very Low Flows

DESCRIPTION & APPLICATION

The LowFlow JRLL Series are low flow regulators designed and built specifically for very low pressure applications. The durable valve body and metal trim components are machined from 316L SST barstock. The valve is outfitted with a sensitive PTFE Jorlon diaphragm for accurate low pressure sensing and Teflon, PEEK, KEL-F and EPDM seats for ANSI Class VI shutoff. USDA and FDA approved soft goods available upon request.

- Ideal for low pressure regulation of gases
- Sparging
- Tank blanketing

INDUSTRIES

- Research and development
- Gas cabinets
- High pressure gas systems
- Injection molding



QUICK SPECIFICATIONS

Seat Type	PTFE, PEEK, KEL-F
Sizes	DN8, DN10, DN15 (1/4", 3/8", 1/2")
End Connections	Threaded, Socket Weld, Flanged, Others
Body Materials	ASTM A479 316L SST, others
Kv (Cv)	0,01, 0,026, 0,07, 0,17 (0.012, 0.03, 0.08, 0.20)
Spring Range	0,7 - 5,2 bar (1 - 75 psi) and 1,7 - 6,9 bar (25 - 100 psi)

KEY FEATURES

- Stable outlet pressure setpoints at very low pressure
- Very low set point offset (droop) especially at higher inlet pressures
- Top entry design facilitates in-line cleaning and maintenance
- Barstock construction guarantees material integrity and quality surface finish
- Jorlon diaphragm material provides exceptionally long life

JRPH / JRPL SERIES (1/4")

Piston Operated

DESCRIPTION & APPLICATION

The DN 8 (1/4") LowFlow JRPH Series and JRPL Series are piston operated pressure regulators that offer excellent control at Kv's of 0,17 (0.20 Cv) and lower. There are six set ranges for the JRPH Series and two set ranges for the JRPL Series. Elastomer seals are used throughout with Buna-N, EPDM and Viton being standard options. USDA and FDA approved soft goods available upon request.

- General, corrosive and specialty gases, water, acids and oils
- High pressure applications

INDUSTRIES

- Gas chromatography
- Flame ionization detectors
- Industrial controls



QUICK SPECIFICATIONS

Seat Type	KEL-F, PEEK
Sizes	DN8 (1/4")
End Connections	Threaded, Socket Weld, Flanged, Others
Body Materials	316L Stainless Steel, Hastelloy C, Monel, Alloy 20, others
Kv (Cv)	0,01, 0,026, 0,06, 0,17 (0.012, 0.03, 0.07, 0.2)
Spring Range	up to 9135 psi (630 bar)

KEY FEATURES

- All wetted materials are 316L Stainless Steel. Other materials available upon application
- Soft PEEK, PTFE or KEL-F seat provides ANSI Class VI shutoff
- Piston sensing for better regulation at higher pressures
- ANSI Class VI shutoff
 - JRPL: PEEK, PTFE, or KEL-F
 - JRPH: PEEK or KEL-F
 - Contact factory for additional options

PRESSURE REGULATING VALVES

JRPH/JRPL SERIES

Piston Operated

DESCRIPTION & APPLICATION

The LowFlow JRPH & JRPL Series are piston operated, balanced trim pressure regulators with high Cvs and KEL-F soft seat for ANSI Class VI shutoff. There are three set ranges for each model. Elastomer seals are used throughout with Buna-N, EPDM and Viton being standard options, along with matching back up seals. USDA and FDA approved soft goods available upon request.

- A variety of gases, water, acids and oil applications
- Fuel cells

INDUSTRIES

- Research and development
- Gas cabinets
- High pressure gas systems
- Injection molding



QUICK SPECIFICATIONS

Seat Type	KEL-F
Sizes	DN15, DN20, DN25 (1/2", 3/4", 1")
End Connections	Threaded, Socket Weld, Flanged, Others
Body Materials	316L Stainless Steel, Hastelloy C, Monel, Alloy 20, others
Kv (Cv)	1,8 (2.1)
Spring Range	up to up to 400 bar (5800 psi)

KEY FEATURES

- All wetted materials are 316L Stainless Steel. Other materials available upon application
- Soft KEL-F seat provides ANSI Class VI shutoff
- Piston sensing for better regulation at higher pressures
- Balanced trim design allows for higher flows

JR-A SERIES

Air Loaded

DESCRIPTION & APPLICATION

The JR-A Series is an air loaded version of the JR Series valve. USDA and FDA approved soft goods available upon request.

- Research and sampling systems
- General, corrosive and specialty gas services
- Non-cavitating liquids

INDUSTRIES

- Gas chromatography
- Flame ionization detectors
- Industrial controls

QUICK SPECIFICATIONS

Seat Type	PTFE, PEEK
Sizes	DN8, DN10, DN15 (1/4", 3/8", 1/2")
End Connections	Threaded, Socket Weld
Body Materials	316L Stainless Steel, Hastelloy C, Monel, Alloy 20, others
Kv (Cv)	0,01, 0,07, 0,17 (0.012, 0.08, 0.20)
Spring Range	up to 52 bar (750 psi)



KEY FEATURES

- Top entry design facilitates in-line cleaning and maintenance
- Barstock construction guarantees material integrity and surface finish
- High flow rate coupled with high rangeability reduces need for reduced trim sizes
- Optimized internal volume
- Proprietary Jorlon diaphragm material provides exceptionally long life
- Sot seat material for ANSI Class VI shutoff

REGULATING VALVES

MK6800HP SERIES

High Pressure Regulating

DESCRIPTION & APPLICATION

The Mark 6800HP Series is a self-operated pressure regulating valve for use on high pressure industrial gas and liquid services to 276 bar (4000 psi). The MK6800HP features exceptional accuracy with high flow capacities and simple in-line maintainability. For durability and dependable service, the DN15 - DN25 (1/2" - 1") valves are constructed of total barstock, with all stainless steel components. Valve plugs are available with either hard or soft seats and balanced trim is available with either seat type. USDA and FDA

approved soft goods available upon request.

- Gas and liquid services (non-cavitating)

INDUSTRIES

- High pressure gas service
- High pressure non-cavitating liquid service



QUICK SPECIFICATIONS

Seat Type	Stellite, Vespel, Teflon
Sizes	DN15, DN20, DN25 (1/2", 3/4", 1")
End Connections	Threaded, Socket Weld, Flanged, Others
Body Materials	316L Stainless Steel, Hastelloy C, Monel, Alloy 20, others
Kv (Cv)	0,4; 0,86; 2,1 (0.5, 1.0, 2.5)
Spring Range	17,2 - 207 bar (250 - 3000 psi)

KEY FEATURES

- Heavy duty construction - barstock body, Stellite trim and high-strain bolting ensuring integrity of pressure containing parts
- Optimized trim design - various piston sizes, spring selections and balanced trim combine to provide excellent performance across a wide range of operating conditions
- Tight shutoff - ANSI Class III, Class IV or Class VI shut-off available
- High pressure - inlet pressure up to 276 bar (4000 psi) with setpoints as high as 207 bar (3000 psi)
- High flows

JB Series

Gas Back Pressure

DESCRIPTION & APPLICATION

The LowFlow JB Series line of back pressure regulators have the ability to handle very high pressures and very low flows. USDA and FDA approved soft goods available upon request.

- Research and sampling systems for corrosive and specialty gases
- Gas chromatography
- Flame ionization detectors
- Industrial controls

INDUSTRIES

- Gas chromatography
- Flame ionization detectors
- Industrial controls

QUICK SPECIFICATIONS

Seat Type	PEEK, KEL-F
Sizes	DN8, DN10, DN15 (1/4", 3/8", 1/2")
End Connections	Threaded, Socket Weld, Flanged, Others
Body Materials	316L Stainless Steel, Hastelloy C, Monel, Alloy 20, others
Kv (Cv)	0,04; 0,13; 0,22; 0,30 (0.05, 0.15, 0.25, 0.35)
Spring Range	up to up to 52 bar (750 psi)



KEY FEATURES

- Top entry design facilitates in-line cleaning and maintenance
- Barstock construction guarantees material integrity and surface finish
- High flow rate coupled with high rangeability reduces need for reduced trim sizes
- Optimized internal volume
- Jorlon diaphragm material provides exceptionally long life
- Soft seat material for ANSI Class VI shutoff

BACK PRESSURE REGULATING VALVES

JBDL SERIES

High Cv Diaphragm

DESCRIPTION & APPLICATION

The JBDL Series is a diaphragm operated, balanced trim, back pressure regulator. The 1,69 Kv (1.95 Cv) offers increased flows across its 83 bar (1200 psi) inlet range, while the KEL-F soft seat provides ANSI Class VI shutoff. Five set spring ranges and three soft seal options offer the customer flexibility in a number of applications and environments. USDA and FDA approved soft goods available upon request.

- Regulate a variety of gases and liquids in compressor control
- Process pressure control where high flows and low pressures are required

INDUSTRIES

- Gas chromatography
- Flame ionization detectors
- Industrial controls



QUICK SPECIFICATIONS

Seat Type	KEL-F
Sizes	DN15 (1/2")
End Connections	Threaded, Socket Weld, Flanged, Others
Body Materials	316L Stainless Steel, Hastelloy C, Monel, Alloy 20, others
Kv (Cv)	1,69 (1.95)
Spring Range	up to 28 bar (400 psi)

KEY FEATURES

- In-line removable plug and trim provides for quick cleaning and maintenance
- Barstock construction guarantees material integrity and surface finish
- Balanced trim offers high flows with minimal lockup
- Optimized internal volume
- KEL-F soft seat for ANSI Class VI shutoff

JBPH Series

Piston Sensed

DESCRIPTION & APPLICATION

The JBPH Series is a piston operated back pressure regulator. The 0,43 Kv (0.5 Cv) offers increased flows across its 414 bar (6000 psi) inlet range, while the KEL-F soft seat provides ANSI Class VI shutoff. USDA and FDA approved soft goods available upon request.

- Research and sampling systems for corrosive and specialty gases
- Gas chromatography
- Flame ionization detectors
- Industrial controls

INDUSTRIES

- Gas chromatography
- Flame ionization detectors
- Industrial controls

QUICK SPECIFICATIONS

Seat Type	KEL-F
Sizes	DN15, DN20, DN25 (1/2", 3/4", 1")
End Connections	Threaded, Socket Weld, Flanged, Others
Body Materials	316L Stainless Steel, Hastelloy C, Monel, Alloy 20, others
Kv (Cv)	0,43 (0.5)
Spring Range	up to 400 bar (5800 psi)



KEY FEATURES

- In-line removable plug and trim provides for quick cleaning and maintenance
- All wetted materials are 316L/316 dual certified Stainless Steel; other materials available on application
- Large 0,43 Kv (0.5 Cv) offers high flows with setpoints up to 400 bar (5800 psi)
- Optimized internal volume
- KEL-F soft seal for ANSI Class VI shutoff
- Captured vent to monitor seal integrity

BACK PRESSURE REGULATING VALVES

Mark 5800HP Series

High Pressure

DESCRIPTION & APPLICATION

The Mark 5800HP Series is a high pressure, back pressure regulator designed to maintain upstream pressure of gases and liquids. As a compact, lightweight product, it is well suited for applications where space and weight are at a premium. The T-bar adjusting handle allows for a lighter spring and more sensitive regulator than models with a fixed knob. USDA and FDA approved soft goods available upon request.

- Higher pressure vessel venting
- High pressure injection applications
- Gas/liquid sampling stations
- Compressor skids
- Test standards

INDUSTRIES

- Gas chromatography
- Flame ionization detectors
- Industrial controls

QUICK SPECIFICATIONS

Seat Type	Teflon (standard), PEEK, Delrin
Sizes	DN15, DN20, DN25 (1/2", 3/4", 1")
End Connections	Threaded, Socket Weld, Flanged
Body Materials	316L Stainless Steel, Hastelloy C, Monel, Alloy 20, others
Kv (Cv)	0,9 (1.0)
Spring Range	27,6 - 345 bar (400 - 5000 psi)



KEY FEATURES

- Complete barstock construction - ensures body/trim material quality and facilitates usage of alloy materials
- Full pressure rating across entire temperature range - maximum setpoints available at maximum pressures
- Proof-tested to 827 bar (12,000 psi) - nearly five times pressure rating, ensures safety when working with high pressures

Mark 5850HP Series

High Pressure

DESCRIPTION & APPLICATION

The Mark 5850HP Series is a high pressure, back pressure regulator designed to maintain upstream pressure of gases and liquids. With a robust piston design, it can handle setpoints up to 345 bar (5000 psig) at 232°C (450°F) with ease. USDA and FDA approved soft goods available upon request.

- High pressure vessel venting
- High pressure injection applications
- Gas/liquid sampling stations
- Compressor skids
- Test standards

INDUSTRIES

- Gas chromatography
- Flame ionization detectors
- Industrial controls



QUICK SPECIFICATIONS

Seat Type	Teflon
Sizes	DN15 (1/2")
End Connections	Threaded, Socket Weld, Flanged, Others
Body Materials	316L Stainless Steel, Hastelloy C, Monel, Alloy 20, others
Kv (Cv)	0,34 (0.4)
Spring Range	55 - 345 bar (800 - 5000 psi)

KEY FEATURES

- Complete barstock construction - ensures body/trim material quality and facilitates usage of alloy materials
- High flow - Kv 0,34 (Cv 0.4) in a compact design
- T-bar handle - allows convenient, precise final setpoint adjustment
- Proof-tested to 1380 bar (20,000 psi) - five times pressure rating, ensures safety when working with high pressures
- A variety of seal materials ensure compatibility with medium



A Division of Richards Industrials
3170 Wasson Road
Cincinnati, OH 45209
USA
Phone: 1.513.533.5600
E-mail: lowflow@richardsind.com
Website: www.lowflowvalve.com