

**Warning:** Jordan LowFlow Control Valves must only be used, installed and repaired in accordance with these Installation & Maintenance Instructions. Observe all applicable public and company codes and regulations. In the event of leakage or other malfunction, call a qualified service person; continued operation may cause system failure or a general hazard. Before servicing any valve, disconnect, shut off, or bypass all pressurized fluid. Before disassembling a valve, be sure to release all spring tension.

### Please read these instructions carefully!

Your Jordan LowFlow Valve product will provide you with long, trouble-free service if it is correctly installed and maintained. Spending a few minutes now reading these instructions can save hours of trouble and downtime later. When making repairs, use only genuine Jordan LowFlow Valve parts, available for immediate shipment from the factory.

### Ideal Installation

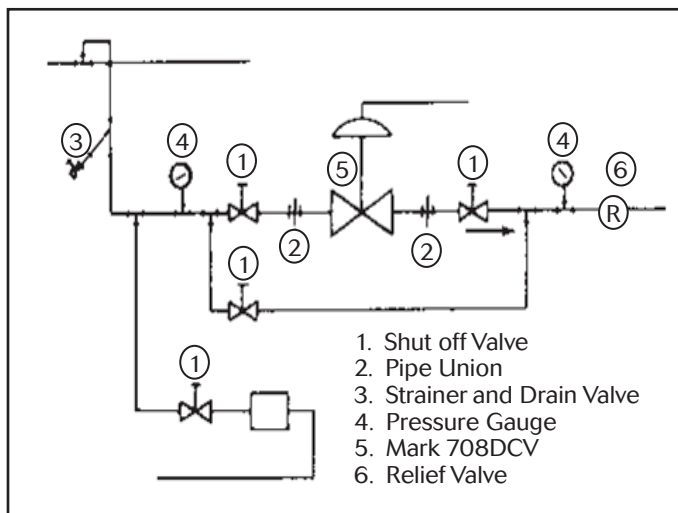

- To control very low flow rates, Mark 708 control valves are often provided with trims having very small clearances. To keep this trim functioning properly, it is essential that the fluid flowing through the valve be clean.
- To protect the valve from grit, scale, thread chips and other foreign matter, ALL pipelines and piping components should be blown out and thoroughly cleaned before the installation process begins.
- Shutoff valves, pressure gauges, and by-pass piping should be installed as indicated in the Installation Schematic to provide easier adjustment, operation and testing.
- A line strainer should be installed on the inlet side of the valve to protect it from grit, scale, and other foreign matter. A 0.033 perforated screen is usually suitable for this purpose. Line strainers are available from Jordan Valve.

- For best control, 3' 0" straight sections of pipe should be installed on either side of the valve.
- In preparing threaded pipe connections, care should be exercised to prevent pipe-sealing compound from getting into pipelines. Pipe sealing compound should be used sparingly, leaving the two end threads clean. Jordan uses, and recommends, thread sealer Teflon ribbon.
- The flow arrow on the valve body must be pointed in the direction of the flow. Ideally the valve should be installed in the highest horizontal line of piping to provide drainage for inlet and outlet piping, to prevent water hammer, and to obtain faster response.
- If possible, install a relief valve downstream from the valve. Set at 15 psi above the control point of the valve.
- In hot vapor lines, upstream and downstream piping near the valve should be insulated to minimize condensation.
- Evaluate inlet and outlet pipe friction losses and velocities to decide when smaller outlet piping might cause excessive back pressure. When required, a standard tapered expander connected to the outlet of the valve is recommended.
- Where surges are severe, a piping accumulator is recommended.
- On steam control applications, install a steam trap with sufficient capacity to drain the coil or condenser. Be sure to have a good fall to the trap, and no backpressure. Best control is maintained if the coil or condenser is kept dry.

### Start-Up Procedure

- Be sure that the action of the control valve and of the controller are such that you achieve the desired results. The action can be changed if needed using the instructions shown in "Reversing Action".

Increase in pressure or temperature must:	And the action of the valve is:	Then the action of the controller must be:
Close Valve	Air to Close (direct)	Direct
Close Valve	Air to Open (reverse)	Reverse
Open Valve	Air to Close (direct)	Reverse
Open Valve	Air to Open (reverse)	Direct

2. The control valve has been pre-set by Jordan Valve, however, finer adjustment may be required to compensate for the system conditions of your application.
3. With inlet, outlet and bypass shutoff valves closed, and no pressure in the down stream line, fully open the outlet valve. Slowly open the inlet valve just enough to start flow through the control valve. Increase the flow gradually by slowly opening the inlet shutoff valve. Do not fully open the inlet valve until you are sure that the controller and control valve have control of the system. Usually, the handwheel on the inlet valve will turn freely when this point is reached.
4. To shut off the line fluid, close the inlet shutoff valve first, and then close the outlet shutoff valve.

---

## Maintenance

---

**Caution: Make certain that there is no pressure in the valve before loosening any fittings or joints. The following steps are recommended:**

1. Close the inlet shutoff valve.
2. Allow pressure to bleed off through the downstream piping. Do not attempt to reverse the flow through the valve by bleeding pressure from the upstream side of the valve.
3. When the pressure gauges indicate that all pressure has been removed from the system, close the outlet shutoff valve, and the valve may be serviced.

**Note: refer to the drawing at the end of this document for description and proper orientation of parts.**

To reduce maintenance time, refer to proper figure and follow steps indicated below for applicable maintenance operation.

Proposed Maintenance Procedure	Follow Steps...
Renewing Stem Packing	Packing Replacement
Valve Disassembly, Inspecting Parts, Replacing Plug or Seat Ring	Valve Disassembly
Valve Reassembly	Valve Reassembly
Actuator Spring Preload Adjustment	Actuator Spring Load Adjustment
Actuator Maintenance	Actuator Maintenance
Motor Valve Seat Spring Preload	Motor Valve Seat Spring Preload

### Packing Replacement

Renew valve plug stem packing if control valve has been in service beyond normal maintenance, and packing shows signs of wear. Wear will be indicated by leakage, which cannot be corrected by minor tightening of the packing flange. An additional packing ring can be installed to overcome minor leakage without dismantling the control valve or breaking valve plug connection.

1. Remove the actuator from the bonnet. (See Removing Actuator from Valve.)
2. Remove all of the packing and discard. Clean valve stem and packing box thoroughly. The valve stem may be dressed with a very fine crocus cloth, but generally it is best not to as the stem has a fine machined finish. Use approved non-residue-forming solvent for cleaning. Wipe dry with clean cloth.
3. Insert a new set of packing in packing box. Press each ring down in place with a tube as it is installed.
4. After packing is installed, assemble packing adapter, gland, and gland nuts. Tighten the nuts hand tight.
5. The final packing adjustment should be made with the valve pressurized and the packing tightened just enough to stop any leakage, while stroking the valve. **Excessive tightening could cause the stem to stick and result in improper valve operation due to high friction forces.**

### Removing Actuator from Valve

- 1a. **Direct Acting Actuator (ATC):** Shut off pressure to the actuator and remove supply tubing from the actuator case.
- 1b. **Reverse Acting Actuator (ATO):** Apply approximately 6 psig air pressure to the actuator to lift the plug off of the seat.
- 1c. **Motor Valve (Mark 708MV):** Position the valve to full open and disconnect all electrical connections.
2. Remove the actuator from the valve as follows: loosen the two stem connector nuts and move them down the stem. Lock these nuts together. Remove the two nuts that secure the packing flange, then the then the two hex bolts that secure the yoke to the bonnet. Remove the gland nuts (8) that secure the packing gland (5) and the packing adaptor (9). Using a wrench on the nuts and on the flats of the actuator stem, turn the stem connector (while holding the actuator stem in place) until the stems disengage. The actuator will be free of the valve.

### Body & Bonnet Disassembly

1. For actuator removal, refer to section on "Removing Actuator".
2. Remove the body/bonnet bolts and *carefully separate the body from the bonnet so as not to damage delicate trim components.*
3. Remove stem nuts and indicator. Withdraw the stem and plug out of the bonnet. (The smaller trims have a one-piece stem and plug, which can be withdrawn through the packing.)
4. With a socket wrench, remove the seat from the body. Remove and discard the body/bonnet gasket.
5. Soft seats are disassembled by removing the seat cap from the seat and then the soft seat can be removed.

6. Clean all parts with an approved non-residue-forming solvent. Remove encrusted material with a very fine Crocus or aluminum oxide cloth. However, do not use these abrasives on the seating surface or the trim surface (the portion of the plug that enters the seat bore.) The machining tolerances on these surfaces are so closely controlled that you might change the valves flow characteristic.
7. Inspect all parts and replace and worn or damaged parts. It is always advisable to replace seals and gaskets. DO NOT attempt to resurface seating surfaces of the plug or seat. Seats and plugs are only sold in factory-matched sets.

### Valve Reassembly

1. Soft seated valves: insert soft seat into the seat cavity, install the seat cap and tighten.
2. Lubricate the seat threads with a lubricant such as NO-LOK and thread the seat into the body. Torque to values shown.

Valve Size	Seat Torque	
	ft. - lbs.	in. - lbs.
1"	26	310

3. Guided trim: coat the guide portion of the plug with MOLYKOTE G-Rapid Spray lubricant or an equivalent light lubricant suitable for your service. Assemble plug to stem. **(If performing Trim Replacement:** Note that the stem and plug are machined to very tight tolerances. If the stem and plug do not assemble smoothly/fully, buff the head of the stem only enough so that the stem head may be inserted in the plug slot and the stem can rotate freely.
4. Insert the stem into the bonnet. Set the gasket around the boss on the bonnet. Carefully assemble the bonnet to the body and allow the plug to center into the seat. Push down on the stem to be sure that the plug has fully engaged the seat. Hand-tighten the body bolts.

Valve Size	Gasket Material	Quantity Required
1"	Teflon	1
1"	Grafoil	2

5. Remove and replace the packing as described in "Packing Replacement".
6. While holding the plug firmly in position in the seat, secure the body to the bonnet with the bolts. Torque bolts evenly to the values shown.

Torque Values (in. - lbs.)		
Material	Bolt Diameter	Limitation
	3/8"	
Gr. BD*	200	650 deg. (also SAE GR. 8)
Gr. B7	200	1000 deg. F
Gr. B6	200	900 deg. F (410 SST)

\* Standard Bolting

7. Reassemble the two stem nuts and indicator all the way onto the stem threads.
8. If the actuator is reverse acting (ATO), apply approximately 6 psig air pressure to the actuator. If MOTOR VALVE, position to full open.
9. Insert hex bolts through the yoke and into the bonnet flange. Next, place the packing adaptor (9) into the packing box, and then the packing gland (5) over the top of the packing adaptor. Secure the packing gland with the gland nuts (8). Thread the stem into the actuator stem. Hold the actuator stem with a wrench to prevent it from turning. Install the nuts onto yoke hex bolts and tighten. (You can press down on the actuator to compress the springs and bring the yoke into contact with the bonnet flange.) The actuator spring preload must be adjusted; refer to "Actuator Spring Preload Adjustment". For Motor Valve see "Motor Valve Seat Spring Pre-Load".

### Actuator Spring Preload Adjustment

1. The two stem nuts should be loosened and threaded down on the stem and then locked together. Lock the valve stem into the stem connector, then thread the stem connector in the actuator stem.
2. A regulated air supply must be provided to the actuator. Connect the air to the lower case for reverse acting or to the upper case for direct action actuators.
3. Standard actuators have ranges of either 3-15 psig or 6-30 psig. The range is stamped on the valve nameplate. These instructions will assume that the range is 3-15. If yours differs, substitute the appropriate pressure where these instructions refer to 3 or 15 psig.
- 4a. **Direct Acting Actuator (ATO):** Slowly increase the air pressure up to 15 psig while observing the stem for movement. Downward travel should stop exactly at 15 psig. If the downward travel stops before 15 psig is reached, thread the stem connector into the actuator stem by wrenching on the locked stem nuts and keeping the actuator stem from turning to avoid twisting the diaphragm and/or toppling the springs. If the downward travel continues after 15 psig is reached, thread the stem connector out of the actuator stem.
- 4b. **Reverse Acting Actuator (ATO):** The valve plug is closed against upward fluid thrust by actuator spring force. Total compression placed on the actuator spring must be sufficient to provide preload plug force required to close the valve. If preload adjustment is made with no pressure in valve body, then, when the control valve is placed in operation, additional compression must be placed on the spring to provide valve closure force. With proper adjustment, valve will close tightly and will not begin to open until the preload pressure is exceeded. Slowly increase the air pressure up to 5 psig while observing the stem for movement. Adjust spring preload until valve just starts to open when 5 psig

air pressure is supplied to the actuator diaphragm. If there is valve movement at less than 5 psig: thread the stem connector out of the actuator stem, wrenching on the locked stem nuts and keeping the actuator stem from turning to increase spring preload. If there is no valve movement at 5 psig: thread the stem connector into the actuator stem, wrenching on the locked stem nuts and holding on to the actuator stem to keep it from moving, to decrease spring preload.

---

## Actuator Maintenance

---

### Disassembly and Inspection of Actuator

Note: The actuator stem has two retaining rings. The purpose of these rings is to maintain compression on the springs (to keep them in place) should the actuator be removed from the valve bonnet. The upper ring functions with reverse action and the lower ring functions with direct acting actuators.

1. Follow instructions under Maintenance section to remove valve from line.
2. Remove the actuator as described in "Removing Valve Actuator".
3. **Direct Acting Actuator (ATC):** separate the cases by removing the bolts. Use a wrench on the flats of the actuator stem to prevent it from turning and remove the bolt and lockwasher. Lift off the diaphragm washer, diaphragm, diaphragm plate, and ThredSeal. Remove the springs. If the actuator stem is to be removed, remove one retaining ring and push the actuator stem out. Remove and discard the o-ring and two backup rings.
4. **Reverse Acting Actuator (ATO):** separate the cases by removing the bolts. Remove the springs. Use a wrench on the flats of the actuator stem to prevent it from turning and remove the bolt and lockwasher. Lift off the diaphragm plate, diaphragm, diaphragm washer, and ThredSeal. If the actuator stem is to be removed, remove one retaining ring and push the actuator stem out. Remove and discard the o-ring and two backup rings.
5. If there is a need to clean the parts, use a solvent that will not harm Buna-N elastomers, such as Stoddard solvent.

### Reassembly of Actuator

- 1a. **Direct Acting Actuator (ATC):** attach the following parts to the top of the actuator stem in the order indicated: ThredSeal, diaphragm plate, diaphragm, diaphragm washer, and lockwasher. Secure them with the bolt. Hold the actuator stem on the wrench flats and tighten the bolts.
- 1b. **Reverse Acting Actuator (ATO):** attach the following parts to the top of the actuator stem in the order indicated: ThredSeal, diaphragm plate, diaphragm, diaphragm washer, and lockwasher. Secure them with the bolt. Hold the actuator stem on

- the wrench flats and tighten the bolt.
- 2a. **Direct Acting Actuator (ATC):** hold this assembly by the bolt head in a vise, stem pointing upward. Install the springs over the dimples in the diaphragm plate. Take the lower case and carefully install it onto the actuator stem by firmly pressing the stem through the stem o-ring seal, keeping the springs in place. Install the retaining ring into the groove in the actuator stem. This will keep the springs compressed and prevent them from coming out of place.
- 2b. **Reverse Acting Actuator (ATO):** install this assembly into the lower actuator case by pressing the actuator stem through the stem o-ring seal. Then install the lower retaining ring onto the actuator plate. Next, install the springs over the dimples in the diaphragm plate.
3. Position the flange of the diaphragm on the flange of the lower actuator case and align the holes. Attach the upper actuator case with the bolts.
4. Reassemble the actuator to the valve as described in "Valve Reassembly" steps 8 & 9.

### Motor Valve Seat Spring Preload

1. Position the valve to be full open.
2. The two stem nuts should be loosened and threaded down the stem and then locked together.
3. Slowly stroke the motor to closed position, while rotating valve stem and stem nuts back and forth (approximately 1/4 turn). Caution: valve stem should rotate freely. When it no longer rotates freely, the plug is in contact with the seat, and the motor must be stopped or damage may occur. If required, the valve stem may be threaded into the actuator stem to allow motor to complete stroke.
4. With motor in full closed position and stopped by limit switch, rotate the stem down until the plug is in contact with the seat, and turn an additional 1/4 - 1/2 turn to preload the seat.
5. Position motor to open position, and confirm that the motor is stopped by the limit switch prior to the plug reaching the upper stop. Without rotating the stem, thread the stem nuts up and lock them against the actuator stem.  
Note: limit switches and high/low set points are factory-set. If command signal range will not fully stroke the valve, refer to electrical connection diagram for the motor actuator that was shipped with the valve. With seat spring preload set, if plug hits upper stop prior to limit switch, the limit switch will require adjustment; consult factory for procedure.

---

## Trim Removal Instructions

---

1. Remove four bolts (4), and remove body.
2. Loosen nut (13A). Keep connector (16) from rotating.
3. DO NOT loosen nuts (13B) as this would change actuator spring adjustment.
4. Unthread stem (17) from connector.
5. Push stem (17) through body. (DO NOT push stem

threads through packing unless stem is being replaced.)

6. Slide plug (14) off stem.
7. Remove and install new seat (18) – optional.
8. Install new gasket (32). Install new packing (12) if stem is removed.
9. Assemble in reverse order. Note: stem must be threaded into connector until bottomed out to maintain stroke adjustment.

---

## Ordering Spare Parts

---

Use only genuine Jordan Valve parts to keep your valve in good working order. So that we can supply the parts, which were designed for your valve, we must know exactly which product you are using. The only guarantee to getting the correct replacement parts is to provide your Jordan Representative with the valve serial number. This number is located on the valve identification tag. If the serial number is not available, the parts needed for your valve might be determined using the following information: Model Number, Valve Body Size, Seat Material and Cv Rating, Spring Range and Set Point, Trim Material, Part Name - Number and Quantity.

NOTE: Any parts ordered without a valve serial number that are found to be incorrect are subject to up to a minimum 25% restock charge when returned.

---

## Trouble Shooting

---

### If You Experience Erratic Control:

- Oversizing can cause cycling or hunting (recalculate the size required).
- Undersizing can cause the control point to drop off under peak loads (increase the trim size).
- Inlet pressure to the valve maybe varying significantly and the controller may not be following it (adjust the controller).
- Control loop may require equal percentage trim if high rangabilities are being utilized.
- Steam traps may need reconditioning.
- Safety relief valves may be leaking.
- Valve stroke may be out of adjustment or there may be foreign matter in the valve preventing full movement.

### If You Experience Insufficient Flow:

- Check shutoff valves to be sure they are fully open.
- Inlet pressure to valve may be insufficient to provide the needed flow (check the inlet pressure with a pressure gauge).
- Strainers should be checked for clogging and blown down if needed.
- Steam traps may need reconditioning.
- Dirt in the trim may prevent the valve from passing its full capacity.
- Diaphragm failure or insufficient air pressure to reverse acting (air-to-open) actuators would prevent

the valve from properly stroking open. Incorrect actuator spring adjustment in reverse acting actuators would prevent the valve properly stroking open.

### If You Experience Overpressure (outlet):

- Dirt in the trim may prevent valve from shutting off.
- Diaphragm failure, incorrect actuator spring adjustment, or insufficient air pressure to direct acting (air-to-close) actuators would prevent the valve from properly stroking closed.

# Mark 708 MAX Packing Assembly for Namur Yoke

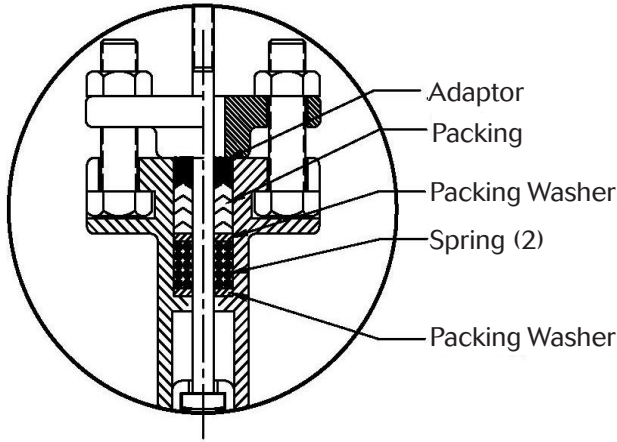

**Standard Packing**

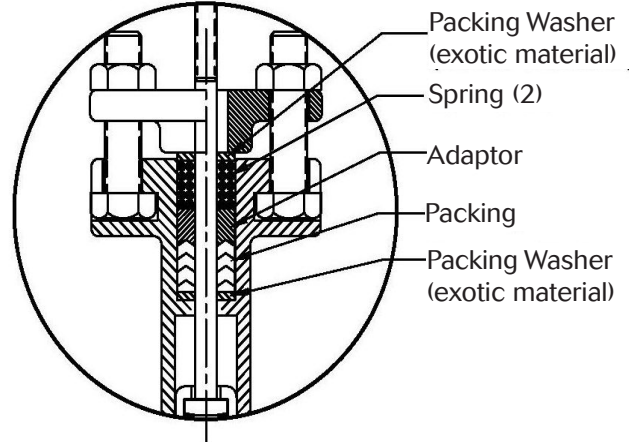

**Inverted Packing - for Exotic Body Material**  
(Put spring on top of packing.)  
(JV P/N 92065)

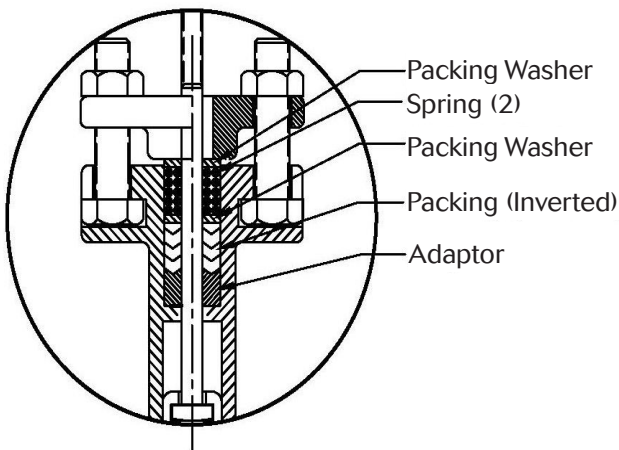

**Packing for Vacuum**  
(Invert packing rings and put spring on top)  
(JV P/N 96071)

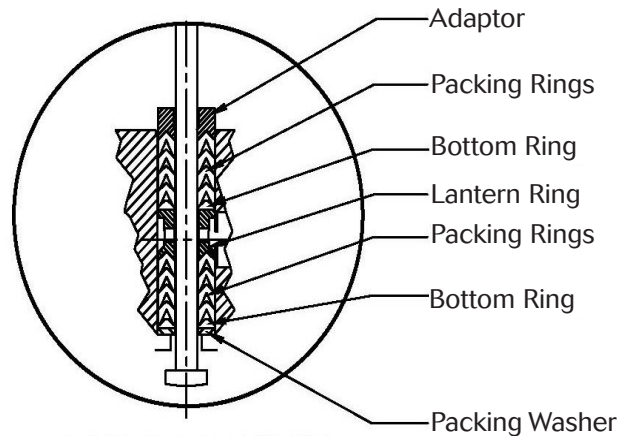

**Double Packing**

## Illustration and Parts List

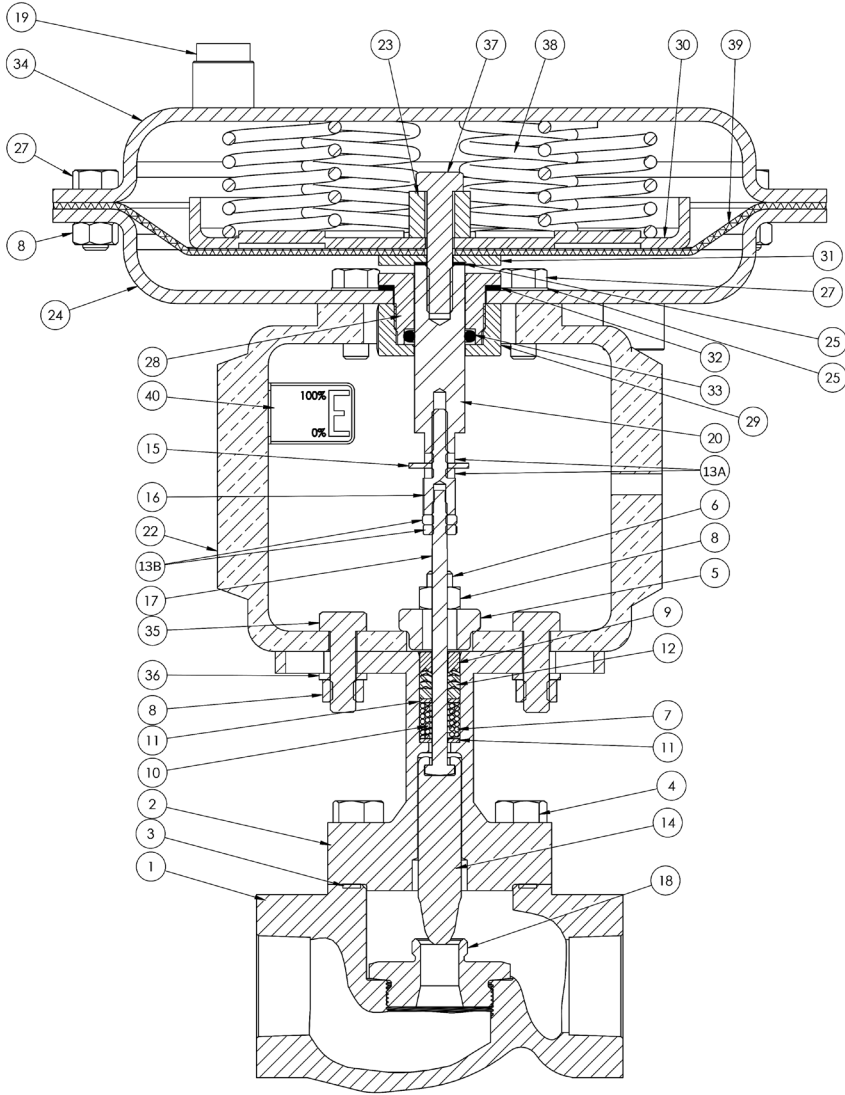

Item	Description	Qty.
1	Body	1
2	Bonnet	1
3	Body/Bonnet Gasket	1
4	HHCS 3/8-16 x 1"	4
5	Gland	1
6	HHCS 5/16-18 x 1-1/4"	2
7	Packing Spring #236	1
8	Hex Nut 5/16-18	12
9	Top Adapter	1
10	Packing Spring #209	1
11	Retaining Washer	1
12	Packing	1
13	Hex Nut 10-24	4
14	Plug	1
15	Washer	1
16	Stem Connector	1
17	Stem	1
18	Seat (see note)	1
19	Vent	1
20	Actuator Stem	1
22	Namur Yoke	1
23	Spacer	1
24	Lower Case	1
25	Fastener Seal	1
27	HHCS 5/16-18 x 7/8"	14
28	Actuator Gland	1
29	Gland Nut	1
30	Diaphragm Plate	1
31	Seal Washer	1
32	Gasket	1
33	O-Ring #208	1
34	Upper Case	1
35	HHCS 5/16-18 x 1"	2
36	Lockwasher 5/16	2
37	HHCS 5/16-18 x 1-1/2"	1
38	Range Spring	6
39	Diaphragm	1
40	Travel Scale	1

Note: Special tool required for seat replacement. Contact factory for details.