



3170 Wasson Road • Cincinnati, OH 45209 USA
Phone 513-533-5600 • Fax 513-871-0105
lowflow@richardsind.com • www.lowflowvalve.com

I & M JRPL Series (1/4")

Installation & Maintenance Instructions for JRPL Series Gas Pressure Reducing Valves

Warning: Low Flow Regulators must only be used, installed and repaired in accordance with these Installation & Maintenance Instructions. Observe all applicable public and company codes and regulations. In the event of leakage or other malfunction, call a qualified service person; continued operation may cause system failure or a general hazard. Before servicing any valve, disconnect, shut off, or bypass all pressurized fluid. Before disassembling a valve, be sure to release all spring tension.

Please read these instructions carefully!

Your LowFlow/Jordan product will provide you with long, trouble-free service if it is correctly installed and maintained. Spending a few minutes now reading these instructions can save hours of trouble and downtime later. When making repairs, use only genuine LowFlow Valve parts, available for immediate shipment from the factory.

Ideal Installation

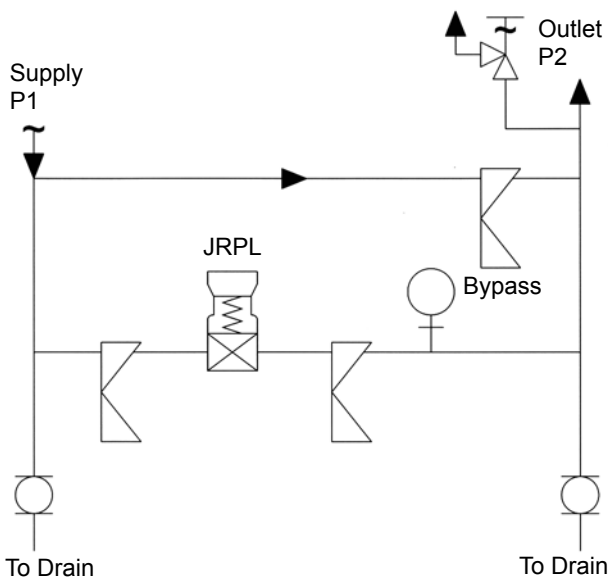

Preferred Installation

Caution! Installation of adequate overpressure protection is recommended to protect the regulator from overpressure and all downstream equipment from damage in the event of regulator failure.

1. An inlet block valve should always be installed.
2. If service application is continuous such that shut-down is not readily accomplished, it is recommended that an inlet block valve, outlet block valve, and a manual bypass valve be installed.
3. An outlet pressure gauge should be located approximately ten pipe diameters downstream, and within sight. If you have ordered your JRPL with

outlet gauge option on the valve outlet, please note that the outlet pressure as registered on the gauge may be slightly higher than a gauge located downstream.

4. All installations should include a downstream relief device if the inlet pressure could exceed the pressure rating of any downstream equipment or the maximum outlet pressure rating of the unit.
5. Flow Direction: install so that the flow direction matches the inlet/outlet marking on the main regulator body (1).
6. For best performance, install in well drained horizontal pipe.
7. Basic regulator - regulator may be rotated around the pipe axis 360°. Recommended position is with knob (5) vertical upwards.
8. Regulators are not to be buried underground.
9. For insulated piping systems, recommendation is to not insulate regulator.
10. Thread seal Teflon ribbon is recommended for all piping and gauge port connections.

Principles of Operation

1. Movement occurs as pressure variations register on the piston (14). The registering pressure is the outlet, P2, or downstream pressure. The range spring (4) opposes piston (14) movement. As outlet pressure drops, the range spring (4) pushes the piston (14) down, opening the port; as outlet pressure increases, the piston (14) pushes up and the port opening closes.
2. A piston o-ring (11) failure will cause the regulator to fail open.

Start Up

Caution! Don't not exceed the maximum rated pressure of the regulator if installed for a hydrostatic test. Isolate the unit if the test is above the valve rating.

1. Start with the block valves closed. A bypass valve may be used to maintain outlet pressure in the downstream system without changing the following steps.
2. Relax the range spring (4) by turning the adjusting

knob (5) counter-clockwise (CCW) until there is no noticeable spring tension.

3. If it is a "hot" piping system, and equipped with a bypass valve, slowly open the bypass valve to pre-heat the system piping and to allow slow expansion of the piping. Closely monitor outlet (downstream) pressure via gauge to ensure no over-pressurizing. Note: if no bypass valve is installed, extra caution should be used in starting up a cold system; i.e. do everything slowly.
4. Crack open the outlet (downstream) block valve.
5. Slowly open the inlet (upstream) block valve observing the outlet (downstream) pressure gauge. Determine if the regulator is flowing. If not, slowly rotate the regulator adjusting knob (5) clockwise (CW) until flow begins.
6. Continue to slowly open the inlet (upstream) block valve until fully open.
7. Continue to slowly open the outlet (downstream) block valve, especially when the downstream piping isn't pressurized. If the outlet (downstream) pressure exceeds the desired pressure, close the block valve and go to Step 2, then return to Step 4.
8. When flow is established steady enough that the outlet (downstream) block is fully open, begin to slowly close the bypass valve if installed.
9. Develop system flow to a level near its expected normal rate, and reset the regulator set point by turning the adjusting knob (5) CW to increase outlet pressure, or CCW to reduce outlet pressure.
10. Reduce system flow to a minimum level and observe set point. Outlet pressure will rise from the set point of Step 9.

Shutdown

1. On systems with a bypass valve, and where system pressure is to be maintained as the regulator is shutdown, slowly open the bypass valve while closing the inlet (upstream) block valve. (When on bypass, the system pressure must be constantly observed and manually regulated.) Close the outlet (downstream) block valve. **CAUTION! Do not walk away and leave a bypassed regulator unattended.**
2. If the regulator and system are to both be shut down, slowly close the inlet (upstream) block valve. Close the outlet (downstream) valve only if regulator removal is required.

Maintenance

Warning! System Under Pressure. Prior to performing any maintenance, isolate the regulator from the system and relieve all pressure. Failure to do so could result in personal injury.

A. General

1. Maintenance procedures hereinafter are based upon removal of the regulator unit from the pipeline where installed.
2. Owner should refer to owner's procedures for removal, handling, cleaning and disposal of non-reuseable parts, i.e. gaskets, etc.

B. Trim Replacement

Note: One of the features designed into the JRPL valves is that a complete trim replacement and wet side cleaning can be done with the valve still installed, without complete disassembly. But please note the caution above. Make sure all upstream and downstream valves are closed and all pressure is relieved prior to beginning work.

1. Remove adjusting screw assembly (5) completely out of the spring housing (6).
2. If valve is removed from the line, clamp the valve in a vise using the body (1).
3. Remove spring housing (6) and upper spring seat (3).
4. Remove range spring (4) and lower spring seat (10).
5. Remove the piston (14) and cylinder (9).
6. Inspect all parts for damage and replace if necessary. Note: Use only parts manufactured and supplied by LowFlow Valve for these parts.
7. Remove seat holder (2), seat (7) and plug (13) from body (1).
8. Place new plug (13) into body chamber. Make sure the bottom stop rod (bigger end) of the plug (13) goes down inside the return spring (16).
9. Place the new seat (7) into the seat holder (2) and carefully install into body cavity (1) taking care not to bend the narrow rod on top of the plug (13) when it passes through the seat holder (2).
10. Separate the piston(14) and cylinder (9) and replace o-rings (11, 12). Place piston (14) into cylinder (9) and install in body (1). Ensure the narrow end of the plug (13) aligns into the counter bore in the piston (14).
11. Replace range lower spring seat (10) and upper spring seat (3) centering both on top of the piston (14). Replace housing (6) and adjusting screw (5). Even if pressure builds up beyond set up, a regulator may or may not develop bubble tight shutoff.
12. Pressurize with air and spray liquid leak detector around body (1) and spring housing (6) to test for leakage. Ensure outlet pressure is maintained during this leak test at mid-range spring level: i.e. 25-100 psig (1,7 - 6,9 barg) range spring, 60 psig (4,3 barg) test pressure minimum.

Troubleshooting

If You Experience Erratic Operation; Chattering:

- A. Oversize regulator; inadequate rangeability
 - 1. Check actuator flow conditions, re-size regulator for minimum and maximum flow.
 - 2. Increase flow rate.
 - 3. Decrease regulator pressure drop; decrease inlet pressure by placing a throttling orifice in inlet piping.
 - 4. Install next step higher range spring. Before replacing regulator, contact factory.
- B. Worn plug or seat; inadequate guiding. Replace trim (possible body replacement).
- C. Weakened/broken return spring. Determine if corrosion is causing plug to not move freely. Replace return spring and spring holder.

If the Regulator can't pass sufficient flow:

- A. Regulator not closing tightly. Inspect plug and seat sub-assembly, replace if worn.
- B. Downstream blockage
 - 1. Check system; isolate (block flow at regulator inlet not outlet).
 - 2. Relocate regulator if necessary
- C. No pressure relief protection. Install safety relief valve, or rupture disc.
- D. Restricted piston movement. Ensure no moisture in spring chamber at temperature below free point.

Illustration & Parts List

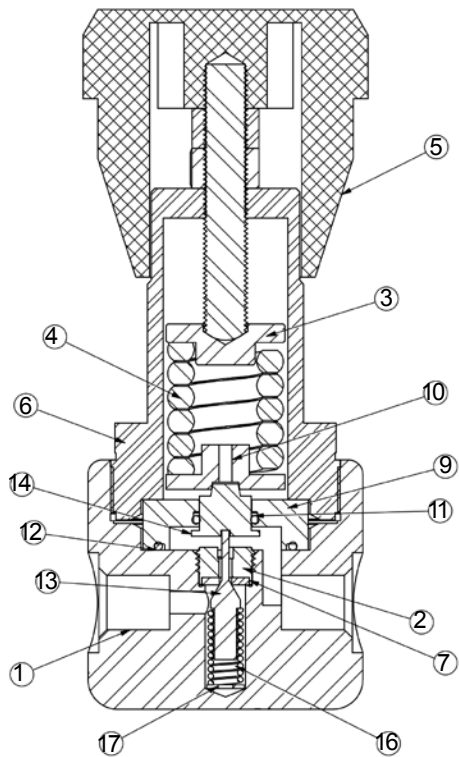

JRPL Standard

Item No.	Description	Quantity
1	Body	1
2	Seat Holder	1
3	Spring Seat	1
4	Range Spring	1
5	Knob Assembly	1
6	Spring Housing	1
7	Seat	1
9	Cylinder	1
10	Spring Seat	1
11	O-Ring #013	1
12	O-Ring #23	1
13	Plug	1
14	Piston	1
16	Return Spring	1
17	Spring Holder	1

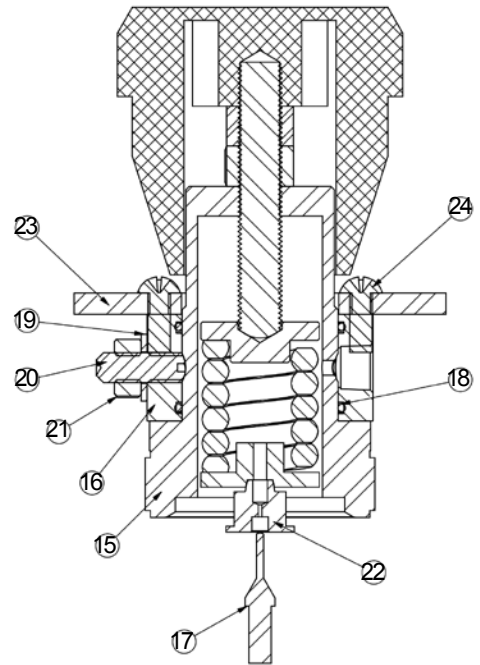

JRPL Captured Vent

Item No.	Description	Quantity
15	Spring Housing	1
16	Cv Collar	1
17	Plug	1
18	O-Ring, #27	2
19	Threadeseal	1
20	SHSS-Cup PT, 1/4-20 x 3/4"	1
21	Hex Nut 1/4-20	1
22	Piston	1
23	Mounting Flange	1
24	SHCS 6-32 x 1/2"	4