

JBDL Series

Back Pressure Regulating Valve

BACK PRESSURE REGULATING VALVE

The JBDL Series is a diaphragm operated, balanced trim, back pressure regulator. The 1.95 Cv offers increased flows across its 1200 psi inlet range, while the Kel-F soft seat provides ANSI Class VI shutoff. Five set spring ranges and three soft seal options offer the customer flexibility in a number of applications and environments. These valves are designed to regulate a variety of gases and liquids from pump and compressor control to process pressure control where high flows and low pressures are required.

Features:

- In-line removable plug and trim provides for quick cleaning and maintenance
- Barstock construction guarantees material integrity and surface finish
- Balanced trim offers high flows with minimal lockup
- Optimized internal volume
- Kel-F soft seat for ANSI Class VI shutoff



JBDL SERIES FLOW CONFIGURATIONS

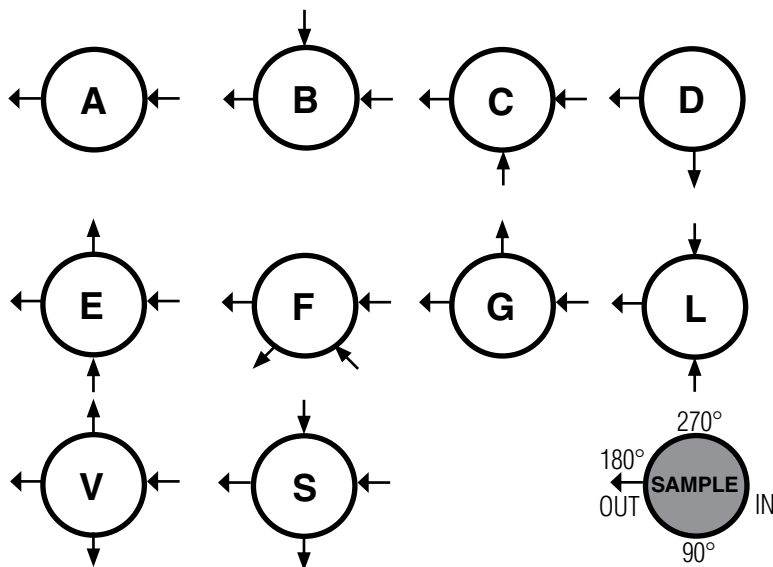

(Top View)
Gage ports are 1/4" FNPT

A Division of
Richards Industrials
3170 Wasson Road
Cincinnati, OH 45209
513.533.5600
lowflow@richardsind.com
www.lowflowvalve.com

JBDL SERIES SPECIFICATIONS

Line Size: 1/2" (DN15)

Materials

- Body & Trim: SS 316L
- Spring Housing: SS 316L
- Plug: 416 SST
- Seat Insert: KEL-F
- Body Seals: Elastomer o-rings (Buna-N, EPDM, Viton) with back up rings
- With PTFE back up rings

Inlet Pressure: 1,200 psi (82,8 bar)

Spring Ranges:

- 0 – 50 psi (0 – 3,45 bar)
- 0 - 100 psi (0 - 6,9 bar)
- 0 - 200 psi (0 - 13,8 bar)
- 0 - 400 psi (0 - 27,6 bar)
- 0 - 730 psi (0 - 50,3 bar)

Seat Diameter: 0.40" (10mm)

Maximum Allowable Pressure: 730 psi (50,3 bar) max ΔP

Maximum Operating Temperature: 600 psi max inlet @ 250°F (41,3 bar max inlet @ 121°C)

End Connections

- Threaded Ends – FNPT or BSPP
- Socket Weld
- Flanged

Gauge Port: 1/4" NPT (optional)

Temperature Range: -29°F to +250°F (-30°C to +120°C) - actual range depends on choice of seal materials

Shutoff: Class VI

Flow Capacity: Cv 1.95 (1,69 Kv)

Optional Cleaning: For oxygen service or oil free service, contact factory

Options:

- Panel Mounting
- Captured Vent
- Locking Wire
- Tamper Proof
- Lockout Device

OPTIONS & DEFINITIONS

Panel Mount: The panel mount feature utilizes a threaded spring housing and a panel mount ring to secure the regulator to an instrument panel. This option requires a 2" panel cut out.

Captured Vent: The captured vent design provides maximum safety for the user when handling toxic or hazardous media. It features a 1/8" FNPT port located on the spring housing. The user can easily tube this vent to a safe location. This option can be incorporated into a self-relieving regulator that provides an additional port to permit the safe expulsion of hazardous media.

Locking Wire: The locking wire option utilizes a lead sealed metal wire to physically hold the adjusting screw in place to prevent any unwanted set point changes.

Tamper Proof: The tamper proof option replaces the standard adjusting knob with a stainless steel acorn nut.

Lockout Device: The lockout device is a 2 piece polypropylene enclosure which encapsulates the adjustment knob and prevents unwanted set point changes. The part number required for this valve is 26971. (Lock not included)

JBDL SIZING

1. Use the "LVCV Sizing Software" link found on the www.lowflowvalve.com home page and navigate to LowFlow valve sizing.
2. Use the software to size for flow using the listed CV of the valve and the customer's application conditions.
3. The JBDL is rated to 50% of the flow value found using LVCV. There is no low-end cutoff limit.

Example:

Air, ambient temperature, P1 = 200 psi, P2 = 0 psi, ½" schedule 40 pipe, flow rate 6,000 SCFH

Using LVCV to size for flow we find that these conditions and a 1.95 CV will result in a maximum flow of 13,742 scfh. Multiply this value by 0.50 to find the maximum rated flow for the JBDL-050-S6. Your result will be 6,871 scfh (13,742 x 0.5 = 6,871). Any flow below this result is acceptable for the valve.

JBDL SERIES FEATURES AND BENEFITS

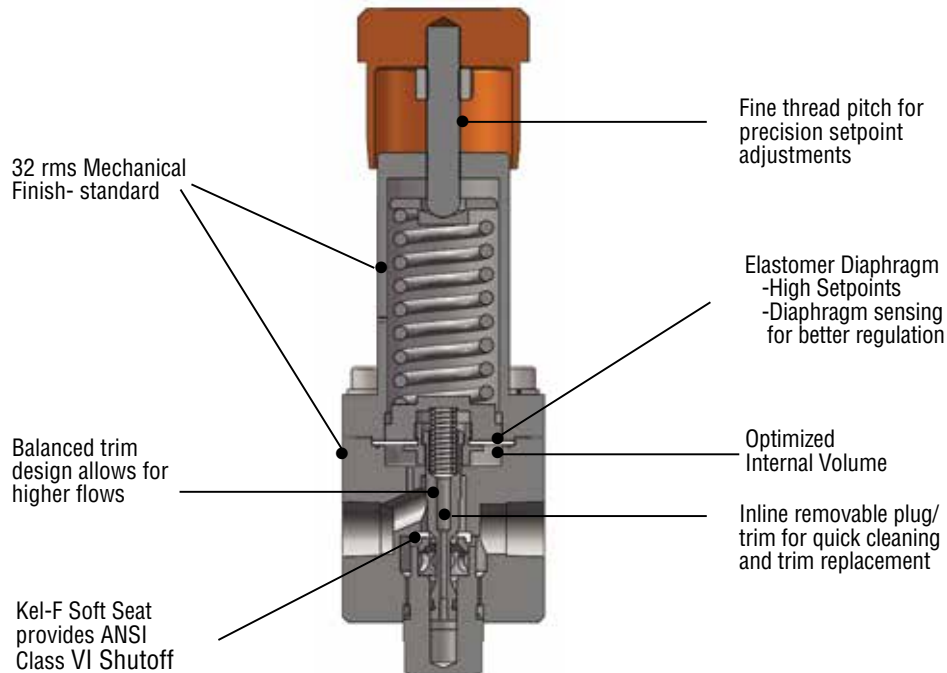

JBDL DIMENSIONS

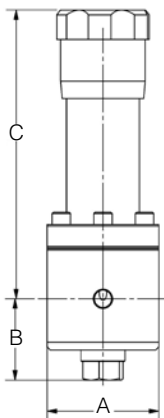

VALVE SIZE	DIMENSIONS, INCHES			WEIGHT, LBS
	A	B	C	
1/2"	2.8	2.1	7.5	7.7

VALVE SIZE	DIMENSIONS, MM			WEIGHT, KGS
	A	B	C	
DN15	71	53	191	3.5

JBDL SERIES ORDERING SCHEMATIC

Model	Size	Material	1 & 2	3 & 4	5 & 6	7 & 8	9 & 10	11 & 12	13 & 14	15	16	17
—	—	—	—	—	—	—	—	—	—	—	—	—

Model	
JBDL	Back Pressure Regulating Valve

Size	
050	1/2"

Material	
6L	Stainless Steel 316L

1 & 2	Body Feature		
End Connection	Port Configuration		
C	FNPT 1/2"	A	Port "A"
F	BSPP 1/2"	B	Port "B"
		C	Port "C"
		D	Port "D"
		E	Port "E"
		F	Port "F"
		G	Port "G"
		L	Port "L"
		V	Port "V"
ZZ		S	Port "S"
		Non-Standard	

3 & 4	Trim
BB	Buna-N
EE	EPDM
ZZ	Non-Standard

5 & 6	Seat
K5	KEL-F Cv 1.95 (1,69 Kv)
ZZ	Non-Standard

7 & 8	Range Spring
E1	0 - 50 psi (0 - 3,45 bar)
E2	0 - 100 psi (0 - 6,9 bar)
E3	0 - 200 psi (0 - 13,8 bar)
E4	0 - 400 psi (0 - 27,6 bar)
E5	0 - 730 psi (0 - 50,3 bar)
ZZ	Non-Standard

9 & 10	Diaphragm
BB	Buna-N
EE	EPDM
ZZ	Non-Standard

11 & 12	Actuator
SK	Standard
CV	Captured Vent
PM	Panel Mount
TP	Tamper Proof
LW	Locking Wire
ZZ	Non-Standard

13 & 14	Inlet Gauge
LL	0 - 60 PSIG/BAR (Dual)
MM	0 - 160 PSIG/BAR (Dual)
PP	0 - 300 PSIG/BAR (Dual)
SS	0-600 PSIG/BAR (Dual)
TT	0-1000 PSIG/BAR (Dual)
VV	0-2000 PSIG/BAR (Dual)
NN	None
ZZ	Non-Standard

* Customer assumes all responsibility for possible damage or injury if selected gauge span does not fully cover range spring / outlet pressure option

15	Outlet Gauge
N	None
Z	Non-Standard

* Customer assumes all responsibility for possible damage or injury if selected gauge span does not fully cover range spring / outlet pressure option

16	SEP Compliance
G	SEP Compliant
0	None
Z	Non-Standard

JBDL SERIES ORDERING SCHEMATIC

Model	Size	Material	1 & 2	3 & 4	5 & 6	7 & 8	9 & 10	11 & 12	13 & 14	15	16	17
—	—	/										

17	Accessories
A	Captured Vent Preset with Anti-Tamper
B	Standard Preset with Anti-Tamper
C	Panel Mount Preset with Anti-Tamper
S	Clean for Oil Free*
X	Clean for Oxygen*
0	None
Z	Non-Standard

*Consult factory for compatible gauge options