

FCI 86-2-201x

FLUID CONTROLS INSTITUTE

REGULATING VALVE TERMINOLOGY

Fluid Controls Institute, Inc.

Sponsor:



Fluid Controls Institute, Inc.
1300 Sumner Ave
Cleveland, Ohio 44115-2851

FCI 86-2-20xx

FLUID CONTROLS INSTITUTE STANDARD
Regulating Valve Terminology

Sponsor

Fluid Controls Institute, Inc.

Fluid Controls Institute

The Fluid Controls Institute is a non-profit trade association of manufacturers of fluid control and conditioning equipment. The FCI is dedicated to the technical advancement of the industry that it serves. The members of the institute have developed standards to help users/purchasers understand and specify correctly Fluid Controls Institute scope products. FCI standards are voluntary standards, and their existence does not in any respect preclude anyone, whether he has approved the standard or not, from manufacturing, marketing, purchasing or using products, processes, or procedures not conforming to the standards. Fluid Controls Institute standards are subject to periodic review and users are cautioned to obtain the latest editions.

CAUTION NOTICE:

This Fluid Controls Institute standard may be revised or withdrawn at any time. The procedures of the Fluid Controls Institute require that action be taken to reaffirm, revise, or withdraw this standard no later than five years from the date of publication. Purchasers of FCI standards may receive current information on all standards by calling or writing the Fluid Controls Institute.

Sponsored and published by:
FLUID CONTROLS INSTITUTE, INC.
1300 Sumner Avenue
Cleveland, OH 44115-2851
Phn: 216/241-7333
Fax: 216/241-0105
E-Mail: fcj@fluidcontrolsinstitute.org
URL: www.fluidcontrolsinstitute.org

Copyright © 201x by Fluid Controls Institute, Inc.
All Rights Reserved

No part of this publication may be reproduced in any form, in an electronic retrieval system or otherwise, without the prior written permission of the publisher.

Suggestions for improvement of this standard will be welcome.
They should be sent to the Fluid Controls Institute, Inc.

Printed in the United States of America

CONTENTS	PAGE
Foreword	vi
1. Introduction	1
2. Scope	1
3. Basic Definition	1
4. Types of Regulating Valves.....	1-7
5. Functional Characteristics	8
6. Performance Characteristics	9-10
7. Part Terminology	10-18
8. Design Features	19
9. Glossary of Non-Standard Terms	19
10. References.....	19-20

Foreword (This foreword is included for information only and is not part of FCI 86-2-201x, *Regulator Terminology*.)

This voluntary standard has been developed by the Regulator Section of the Fluid Controls Institute to establish common and preferred terminology for regulators. This standard addresses the following major areas: types of regulators, functional characteristics, performance characteristics, part terminology, and design features.

This standard incorporates information previously contained in FCI 55-1, 58-1, 70-1, and 71-1. An attempt has also been made to utilize existing terminology contained in publications of recognized technical or trade associations.

The following types of devices are excluded from the standard:

- Control Valves
- Safety Valves
- Safety Relief Valves
- Level Regulators
- Regulators for Fuel Gases

FCI recognizes the need to periodically review and update this standard. Suggestions for improvement should be forwarded to the Fluid Controls Institute, Inc., 1300 Sumner Avenue, Cleveland, Ohio 44115-2851. All constructive suggestions for expansion and revision of this standard are welcome.

The existence of a Fluid Controls Institute (FCI) standard does not in any respect preclude any member or non-member from manufacturing or selling products not conforming to this standard nor is the FCI responsible for its use.

FLUID CONTROLS INSTITUTE

Regulating Valve Terminology

1 INTRODUCTION

The terminology in this standard is intended to establish a common and preferred usage of terms as they apply to fluid regulating valves (regulators). Many of the terms are identical to, or have direct counterparts with, control valve terminology. ISA-S75.05 "Control Valve Terminology" has been used as a reference.

2 SCOPE

To provide basic regulator definitions and terminology relating to types, function, performance, parts, and design features.

3 BASIC DEFINITION

Regulator -- A self-operated, modulating valve powered by the potential, kinetic, or thermal energy of the flowing fluid.

4 TYPES OF REGULATORS

4.1 Flow Regulator -- A regulator which maintains a constant rate of fluid flow while compensating for system pressure changes. See Fig. 1.

4.2 Pressure Regulation

This section defines regulators in which power to modulate the valve is provided by the pressure of the controlled variable.

4.2.1 Pressure Regulator (Pressure Reducing Valve, Pressure Reducing Regulator) -- A regulator that controls and responds to changes in its downstream pressure. See Fig. 2.

4.2.2 Back Pressure Regulator -- A regulator that controls and responds to changes in its upstream pressure.

4.2.3 Differential Pressure Regulator -- A regulator that maintains a constant differential pressure between a reference pressure and the pressure of the controlled fluid.

4.2.4 Pump Pressure Regulator -- A regulator that controls and responds to pump discharge pressure.

4.2.5 Vacuum Regulator/Breaker -- A regulator that controls pressure less than atmospheric pressure.

4.2.6 Absolute Pressure Regulator -- A regulator that controls pressure using absolute pressure rather than atmospheric (gauge) pressure as a reference.

4.2.7 Booster Relay -- A form of regulator that provides a higher flow volume output than the signal source to which it responds at a pressure proportional to the signal.

4.2.8 Computing Relay -- A form of regulator that generates an output signal in a defined mathematical relationship to an externally applied signal or signals.

4.2.9 Ratio Relay -- See 4.2.8. A form of computing relay which generates an output signal in a fixed ratio to the input signal.

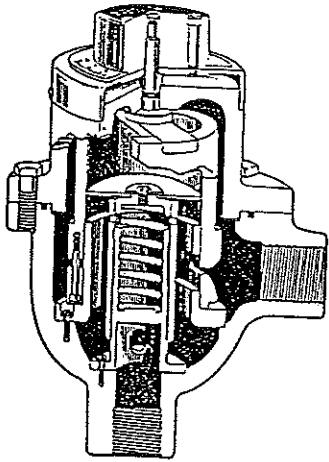

Figure 1 – Flow Regulator

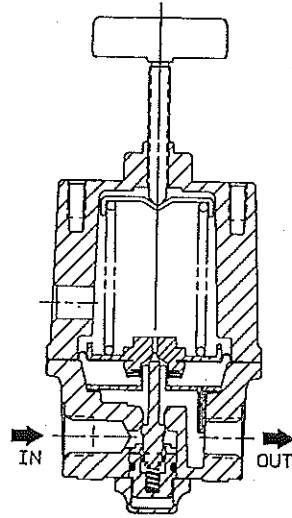

Figure 2 – Pressure Regulator

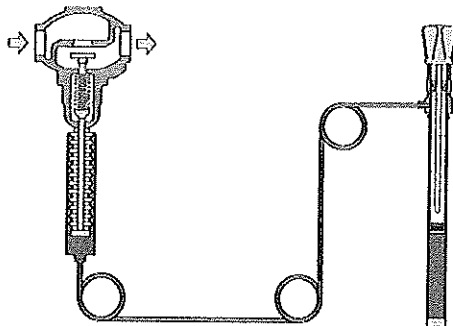

Figure 3 – Temperature Regulator,
Direct Acting

4.3 Temperature Regulation

This section defines regulators in which power to modulate the valve is provided by the temperature of the controlled variable.

4.3.1 Temperature Regulator, Direct-Acting -- A regulator that modulates towards closing on temperature rise. See Fig. 3.

4.3.2 Temperature Regulator, Reverse-Acting -- A regulator that modulates towards opening on temperature rise.

4.4 Pilot-Operated Regulators

Pilot-operated regulators are a combination of modulating valves using a primary regulator (pilot valve or pilot) to power a signal-amplifying section of a secondary regulator (main valve). The pilot may be internal or external.

4.4.1 Pilot-Operated Temperature Regulator -- A regulator using a temperature-sensing pilot valve to provide amplifying flow to modulate the main valve. The pilot valve responds to temperature changes in the controlled variable and uses fluid pressure inside its thermal-sensing element to actuate the pilot, thereby obtaining the pilot flow that modulates the main valve. See Fig. 4

4.4.2 Pilot-Operated Pressure Regulator - A regulator using a pressure-sensing pilot to provide amplifying flow to modulate the main valve.

The pilot valve responds to pressure changes in the controlled variable and uses fluid pressure inside a diaphragm or bellows chamber to actuate the pilot, thereby obtaining the pilot flow that modulates the main valve. See Fig. 5

4.4.3 Combination Pressure-Temperature Regulator -- A multi-function, pilots-operated regulator using both a pressure-sensing pilot and temperature-sensing pilot to provide amplifying flow to modulate the main valve.

The pilot valves respond to respective pressure and temperature changes in the controlled variable, thereby obtaining the pilot flow that modulates the main valve. See Fig. 6.

4.4.4 Combination Pressure-Backpressure Regulator -- A multi-function, pilots-operated

regulator using both a pressure-sensing pilot and backpressure-sensing pilot to provide amplifying flow to modulate the main valve.

The pilot valves respond to respective pressure and backpressure changes in the controlled variable thereby obtaining the pilot flow that modulates the main valve. See Fig. 7.

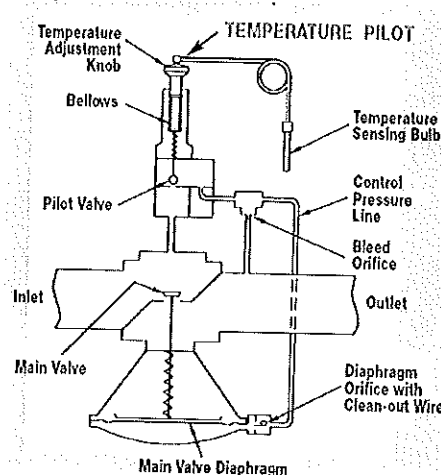
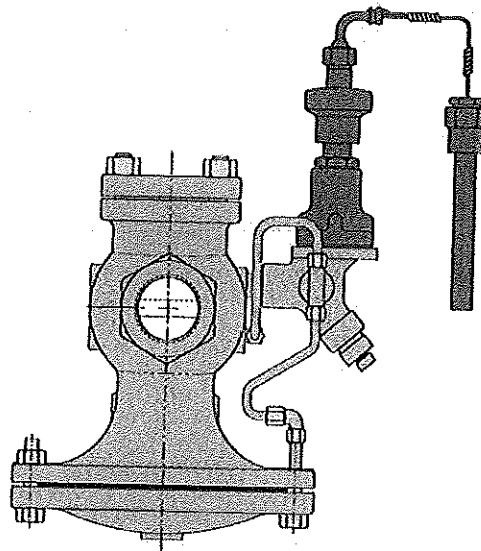

Figure 4 – Pilot Operated Temperature Regulator

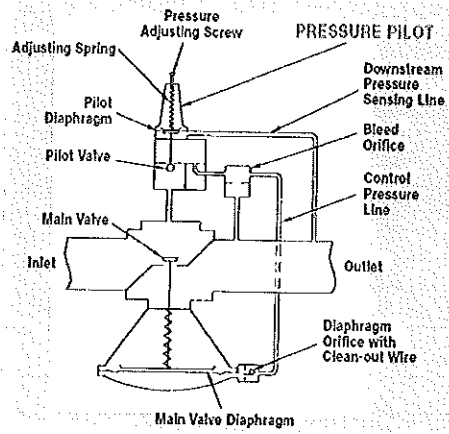
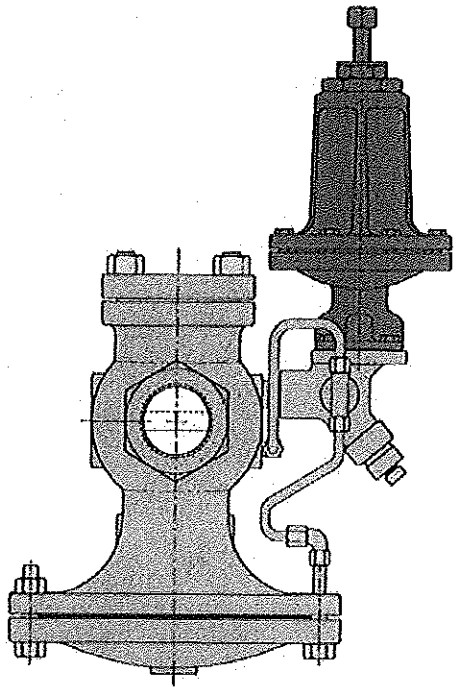

Figure 5 – Pilot Operated Pressure Regulator

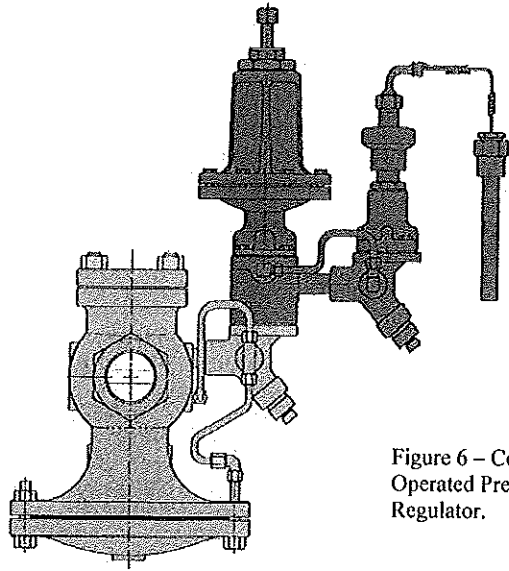

Figure 6 – Combination Pilot Operated Pressure/Temperature Regulator.

5 FUNCTIONAL CHARACTERISTICS

5.1 Bellows Actuated Regulator -- A regulator utilizing a bellows as the plug positioning actuator. See Fig. 3.

5.2 Diaphragm Actuated Regulator -- A regulator utilizing a diaphragm as the plug positioning actuator. See Fig. 7.

5.3 External Piloted Regulator -- A piston or diaphragm actuated regulator controlled by a separate external pilot mechanism(s). See Fig. 7.

5.3.1 External Pressure Loaded Regulator -- A pressure loaded regulator that has its loading pressure adjusted by an instrument regulator for its set point reference to accomplish pressure reduction, back pressure, differential pressure or temperature regulation.

5.3.2 Spring Loaded Externally Piloted Regulator -- A regulator that utilizes a spring loaded external pilot mechanism to accomplish pressure

reduction, back pressure regulation, differential pressure or temperature regulation.

5.4 5.3.4 Pressure Dome Loaded Regulator -- A regulator using a compressed fluid (usually air) instead of a spring as a set point reference to accomplish pressure reduction or back pressure regulation. Sometimes called a Dome Loaded Regulator.

5.45 Internal Pilot Diaphragm Actuated Regulator -- A regulator, utilizing a diaphragm as the actuator for the plug, controlled by an integral pilot mechanism.

5.56 Internal Pilot Piston Actuated Regulator -- A regulator, utilizing a piston as the actuator for the plug, controlled by an integral pilot mechanism(s). See Fig. 8.

5.67 Piston Actuated Regulator -- A regulator utilizing a piston as the plug positioning actuator. See Fig. 8.

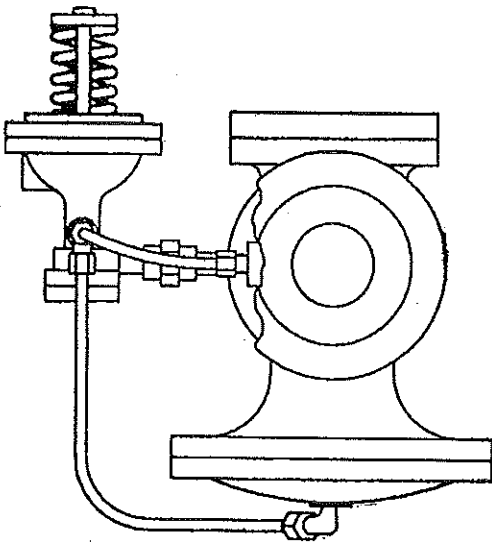

Figure 7

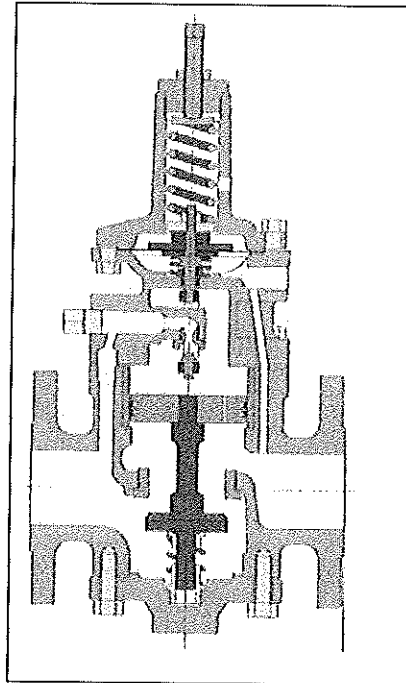

Figure 8

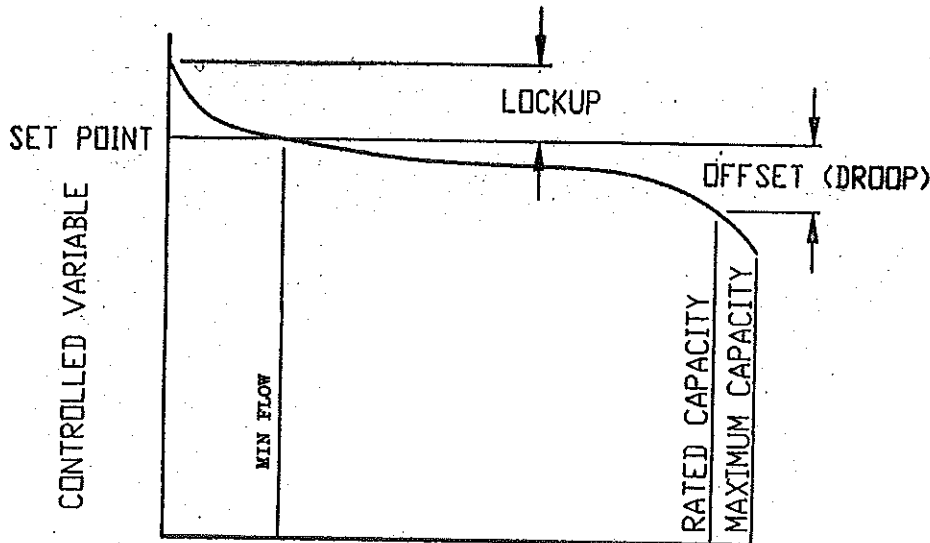

Figure 9

6 PERFORMANCE CHARACTERISTICS

See Fig. 9 for an illustration of terms 6.2, 6.8, 6.14, 6.15, and 6.22 inclusive.

6.1 Accuracy -- Conformity of an actual value to a standard or an ideal value.

6.1.1.2 Accuracy of Regulation -- The deviation from the set point expressed as a percentage or as a fixed unit, taken at the test conditions. See Fig. 9.

6.1.2 Droop The change in controlled variable from set point with respect to increasing flow rate.

6.2.3 Aspirator (Velocity Boosting) -- Any pressure measurement method using fluid velocity effect to produce a pressure feedback that enhances accuracy of regulation.

6.2.4 Controlled Bleed -- A controlled leak-off used to keep a regulator in operating mode to enhance responsiveness.

6.5 Creep -- See drift.

6.46 Dead Band -- The range through which an input can be varied without initiating an observable response.

6.7-5 Drift/Creep -- A change in set point over an extended period of time. A deviation in outlet pressure of a regulating device caused by contamination, damage, or misalignment of its plug-seat relationship.

6.86 Flow Capacity -- The rate of flow through a regulator under stated opening and conditions of inlet and outlet pressures.

6.68.1 Rated capacity of a differential pressure regulator for specified inlet condition and fluid is the rate of flow obtainable through the regulator when the regulated differential pressure deviates by a stated number of units from the differential pressure as set originally at the minimum controllable flow.

6.68.2 The rated capacity of a flow regulator is the flow which the regulator will maintain within its defined accuracy limits while the system's operating pressure varies between specified limits. See Fig. 9.

6.68.3 Rated capacity of a pressure regulator for specified inlet condition and fluid is the rate of flow obtainable through the regulator when the regulated pressure deviates by a defined number of units from the pressure as set originally at the minimum controllable flow.

6.68.4 Rated capacity of a temperature regulator for specified inlet condition and fluid is the rate of flow obtainable through the regulator when the regulated temperature deviates by a defined number of degrees from the temperature as set originally at the minimum controllable flow.

6.97 Flow Coefficient (Cv) -- The regulator capacity in GPM of water at 20°C with one PSI pressure drop at full rated travel. Refer to ISA S75.01.01 and S75.02.01 for testing procedures and sizing equations.

6.8 Maximum C_v -- Maximum C_v is C_v at maximum capacity calculated per ISA 75.01.01 generally used for relief valve sizing.

6.240 Flow Rate -- The number of units of fluid passing through a channel in a unit of time.

6.104 Hysteresis -- The maximum difference between increasing and decreasing output values for any single input during a calibration/operational cycle, excluding errors due to dead band.

6.112 Inlet Sensitivity -- For a given flow rate, the ratio of change in outlet pressure to a change in inlet pressure. The ratio may be direct or inverse.

6.121.1 Direct Ratio -- Where the change in outlet is in the same direction as the change in inlet.

6.112.2 Inverse Ratio -- Where the change in outlet is in the opposite direction as the change in inlet.

6.132 Leakage -- Flow of fluid past a seat or seal, in the closed position. Refer to ANSI/FCI 70-3 for leakage categories.

6.143 Lockup -- Deviation from value at minimum controllable flow (6.3) when the regulator is at no flow condition. See Fig. 9.

6.145 Minimum Controllable Flow -- The lowest flow at which a steady regulated condition of the controlled variable can be maintained.

6.156 PMA (Maximum Allowable Pressure) -- Maximum pressure that the shell of the regulator can withstand at a given temperature.

6.167 PMO (Maximum Operating Pressure) -- Pressure for which a regulator is designed to operate by the manufacturer.

6.178 Pressure (gauge) -- Pressure measured relative to the atmospheric pressure (atmospheric pressure being defined as zero). Abbreviated as 'psig'.

6.189 Pressure (absolute) -- The gauge pressure plus the barometric or atmospheric pressure. Abbreviated as 'psia'.

~~6.1920 Offset (droop) -- The change in controlled variable from set point with respect to increasing flow rate. See Droop (Section 6.1.2).~~

6.204 Repeatability -- The variance of the controlled variable at steady state conditions when returned to the same steady-state conditions after an upset(s).

6.212 Resolution Sensitivity -- The smallest change in the controlled variable to which the regulator will respond.

6.223 Set Point -- The initial setting of the regulator to achieve the desired controlled variable at a specified flow and inlet pressure.

6.234 Specific Gravity -- The ratio of the density of a given fluid to another at a specified temperature. For liquids the reference fluid is water; for gases the reference fluid is air.

6.245 Stability -- Ability to hold a steady controlled variable within the limits of stated accuracy of regulation.

6.256 TMA (Maximum Allowable Temperature) -- Maximum temperature to which the shell of the regulator can be raised permanently.

6.267 TMO (Maximum Operating Temperature) -- Temperature for which a regulator is designed to operate by the manufacturer.

7 PART TERMINOLOGY

7.1 The following terms apply to pressure and temperature regulators. The terms have been

Formatted: Subscript
Formatted: Subscript
Formatted: Subscript

restricted to functional components common to most regulators. Many existing terms are long standing and are common to most suppliers. Other terms, where no common accepted terminology existed, have been chosen to be broadly applicable and functionally descriptive rather than unique details of specific designs. See Fig. 10.

7.1.1 Adjusting Screw or Adjusting Handwheel -- A means for compressing a loading spring and establishing a set point of the regulator.

7.1.2 Adjusting Spring -- A means of providing a reference load (force) to establish the set point of the controlled variable.

Xxx Base Test Pressure for Hydrostatic Production Tests -- This shall be determined from the maximum operation pressure for the pressure regulator shell under test. For pressure regulator body shells this should be the maximum operating pressure for the body's pressure shell or the body's flange pressure rating, whichever is less.

7.1.3 Bonnet -- A pressure containing closure that can be removed from the regulator to allow access to the internal components.

7.1.4 Bottom Spring Seat -- Acts as a guide for the adjusting spring and transmits spring force to the pilot plug.

xxx Buidup -- The deviation of the controlled variable measured as the flow varies from the minimum controllable-set flow to the rated capacity.

Xxx Bulb Diameter -- The bulb diameter is the outside diameter of the sensing portion.

Xxx Bulb Extension -- An extension is that portion of a bulb which extends between the sensing portion and the connector. This extension length is usually defined and will vary with the application.

7.1.5 Diaphragm -- A flexible pressure-responsive element which transmits force to another member.

7.1.6 Diaphragm Plate or Piston -- A support plate concentric with the diaphragm for transmitting force.

7.1.7 Guide Bushing -- A part that constrains movement of another part in a desired path.

7.1.8 Liner -- A replaceable cylinder with a smooth internal bore which guides a piston and allows for good sealing of the piston seals.

7.1.9 Lock Cap -- A tamper proof cap to prevent unauthorized adjustments of set point.

7.1.10 Lock Nut -- Means for preventing accidental changes in set point due to vibrations.

7.1.11 Pilot Housing -- Pressure containing member with a number of ports (passages that allow the transfer of fluid) that allow the pilot to sense the controlled variable and operate the main valve.

7.1.12 Pilot Plug -- A closure member that controls the operation of the main valve.

7.1.13 Pilot Plug Spring -- A spring that provides the force to push the pilot plug toward the closed position.

7.1.14 Pilot Seat -- An orifice that has its effective cross-sectional area adjusted by the pilot plug through which the fluid media flows to control the main valve.

7.1.15 Piston -- A pressure responsive element which transmits force to another member.

7.1.16 Piston Rings -- Dynamic sealing members.

7.1.17 Plug -- A moveable part which provides variable restriction in the valve seat.

7.1.18 Plug Spring -- A spring that provides force to move the valve plug.

7.1.19 Seat Ring -- An orifice (sometimes referred to as a port) that has its effective cross-sectional area adjusted by a plug to vary fluid flow.

7.1.20 Spring Housing -- A structural part that houses a spring and may also serve other functions.

7.1.21 Spring Seat -- Acts as a guide for a spring and transmits the spring force to another member.

7.1.22 Valve Body -- A pressure containing housing for internal valve parts having inlet and outlet flow connections.

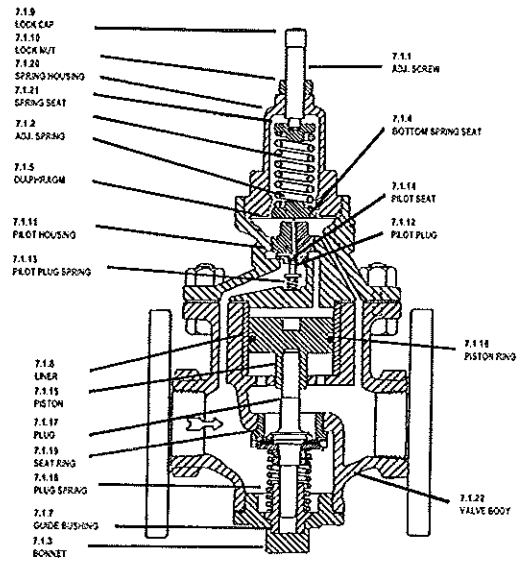

Figure 10

7.2 Terms Applicable to Flow Regulators. See Fig. 11.

7.2.1 Body -- The portion of the lower half of the pressure retaining shell enclosing the working mechanism regulator's main valve trim.

7.2.2 Bonnet -- The upper half of the pressure retaining shell enclosing the working mechanism. To be revised.

7.2.3 Buildup -- The deviation of the controlled variable measured as the flow varies from the minimum controllable set flow to the rated capacity.

7.2.3 Disc (Piston) -- The movable part, located between the upstream and downstream pressures of the orifice, which moves or drives the regulating valve.

7.2.4 Orifice Cylinder -- The cylindrical member within the orifice sleeve, supporting it and with it forming the measuring orifice.

7.2.5 Orifice Sleeve -- The sleeve that contains the orifice which measures the flow being controlled.

7.2.6 Setting Knob Assembly -- The knob and calibrated dial assembly for changing the set point.

7.2.7 Spring -- Part which exerts force counter to the differential pressure across the measuring orifice.

7.2.8 Spring Adjuster -- Means provided for compressing the spring to balance the differential pressure.

7.2.9 Trim -- The internal components of a valve that modulate the flow of the controlled fluid.

7.2.9 Valve Sleeve -- The tubular part supported by and sliding on the valve tube to form the regulating valve.

7.2.10 Valve Tube -- The tubular part supporting the valve sleeve and with it forming the regulating valve.

Formatted: Highlight

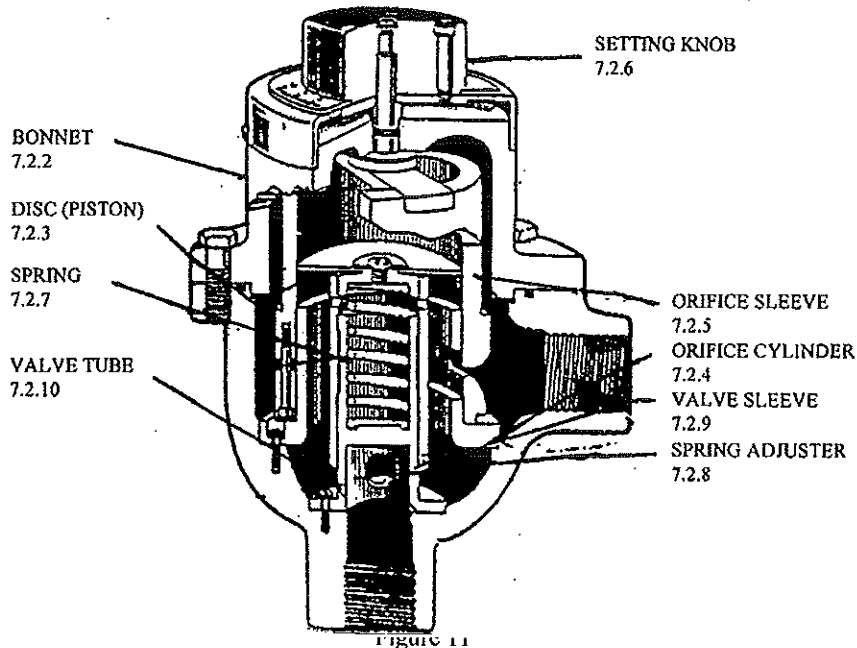

7.3 Terms Applicable to Temperature Regulators

7.3.1 Armor -- A heavy flexible interlocked spiral metal which protects covering which protects the capillary. See Fig. 15.

7.3.2 Bendable Extension -- An extension designed to be bent at the time of installation.

7.3.3 Bulb -- The sensing means of a thermal system. Depending on the design, a portion or the entire length of the bulb must be immersed in the fluid to sense its temperature. The bulb may be plain or have a connector (e.g. union) to attach it to a vessel.

7.3.4 Bulb Diameter -- The bulb diameter is the outside diameter of the sensing portion.

7.3.4 Bulb Extension -- An extension portion of a bulb which extends between the sensing portion of the bulb and the connector. See Fig. 16.

7.3.5 Bulb Extension Length -- The length from the sensing portion of the bulb to the connector. See Fig. 16.

7.3.3 BULB

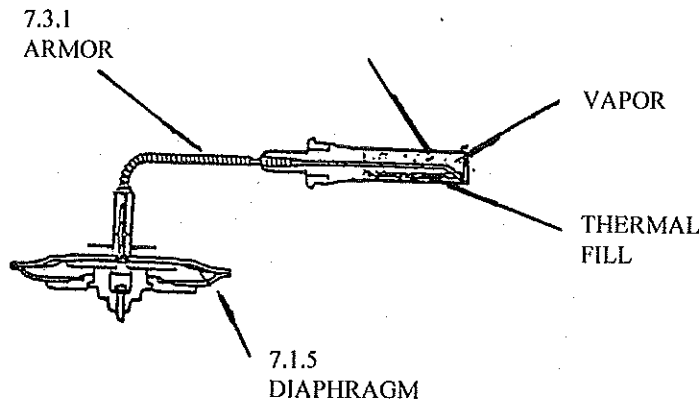

Figure 12

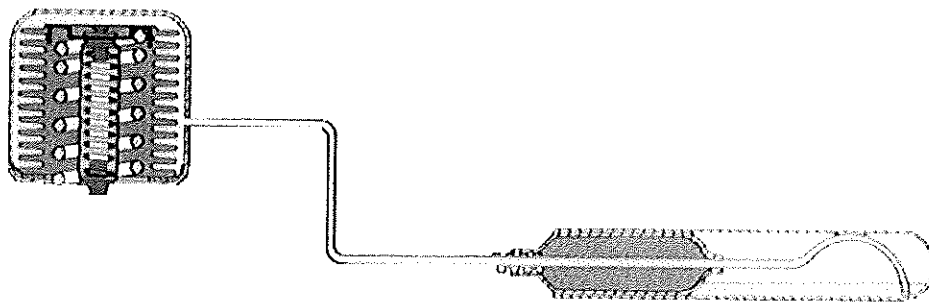

Figure 13

7.3.6 Bulb Immersion Length -- The length from the free end of the bulb to the point of immersion in the fluid being sensed. See Fig. 16. The bulb immersion length must equal or exceed the bulb sensing portion.

7.3.7 Bulb Insertion Length -- The length from the free end of the bulb to, but not including, the external threads of the bushing or other means of attachment to a vessel. See Fig. 16.

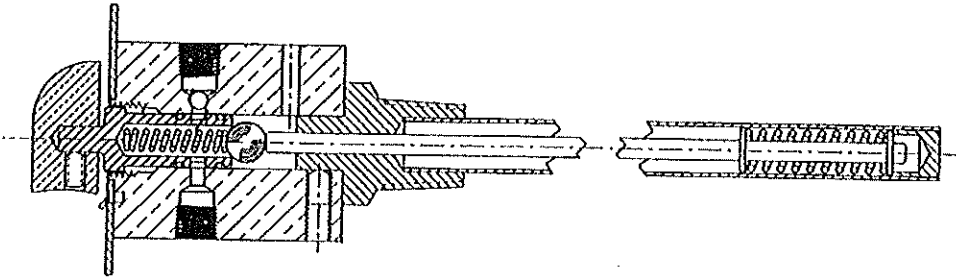

Figure 14

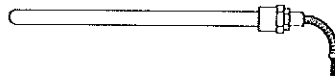

Figure 15

7.3.8 Bulb Length -- The bulb length of a plain bulb is the overall length. The bulb length of a union connected bulb is the length from the free end of the bulb to the underside of the seating part of the bushing. See Fig. 17.

7.3.9 Bulb Sensing Portion -- That portion of a bulb enclosing the fluid fill intended to sense temperature. See Fig. 16.

7.3.10 Bushing -- A fitting provided with external threads or other seating means for mounting a union connected bulb. See Fig. 16.

7.3.11 Capillary -- A tubing, normally flexible, connecting the bulb to the expansion device in the actuator. The energy of the fluid fill is transmitted through the capillary tubing to the expansion device, which in turn positions the valve plug. See Fig. 17.

7.3.12 Coated Bulb -- A bulb coated with a corrosion resistant material not affected by the fluid media in which it is to be immersed.

Xxx Controlled Variable -- The variable which shall be monitored by the controlling process. This variable is either the outlet pressure, inlet

pressure or the differential pressure, temperature or controlled variable. To be revised.

Formatted: Highlight

7.3.13 Flow Control Mechanism -- Closure device positioned by temperature energy controlled variable.

7.3.14 Guiding Bushing -- A device that supports and/or guides moving parts such as valve stems or shafts.

7.3.145 Lagging Extension -- That portion of the bushing or well above the external threads, intended to extend through the lagging (insulation) of a vessel or pipe. See Fig. 18.

7.3.156 Lagging Extension Length -- The length from the lower end of the external threads of a bushing or well to the upper end of the portion intended to extend through the lagging of a vessel, less one inch allowance for threads. See Fig. 18.

7.3.167 Plain Bulb -- A bulb not provided with a union connection or other means for attachment to a vessel.

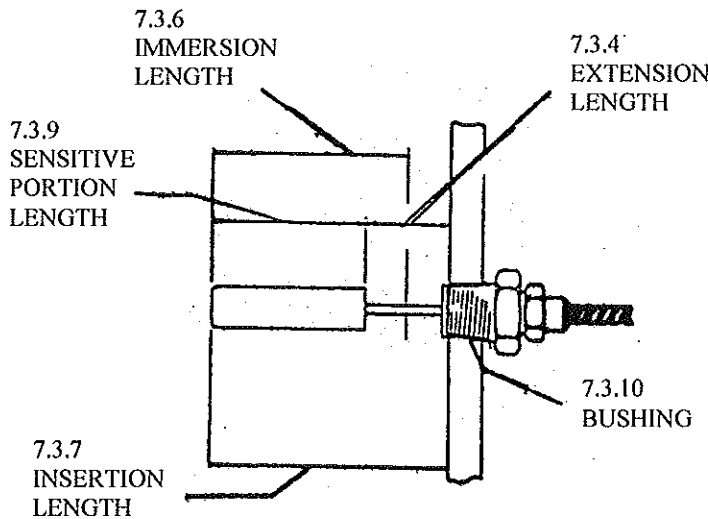

Figure 16

7.3.178 Rigid Extension -- An extension not designed to be bent at the time of installation.

7.3.189 Sanitary Bulb -- A bulb for use where sanitary requirements must be met. Designed to prevent introduction or retention of foreign matter and to facilitate cleaning.

7.3.1920 Temperature Set Point Mechanism -- A device for setting the value of temperature.

7.3.201 Thermal System -- A system designed to activate a control mechanism in response to temperature changes in the controlled medium.

7.3.201.1 Bi-metallic Thermal System -
- A device working on the difference in coefficient of expansion between two metals to produce the power to position a valve plug in response to temperature change. See Fig. 14.

7.3.201.2 Liquid Expansion Thermal System -- A closed system containing liquid. The expansion and contraction of the liquid in response to temperature changes provides the power to position a valve member. See Fig. 13.

7.3.201.3 Vapor Pressure Thermal System -- A closed system containing a volatile fluid. The vapor pressure of the fluid changes with temperature to provide the power to position the valve plug. See Fig. 12.

7.3.224 Union Connected Bulb -- A bulb provided with a pressure tight union connection for installation.

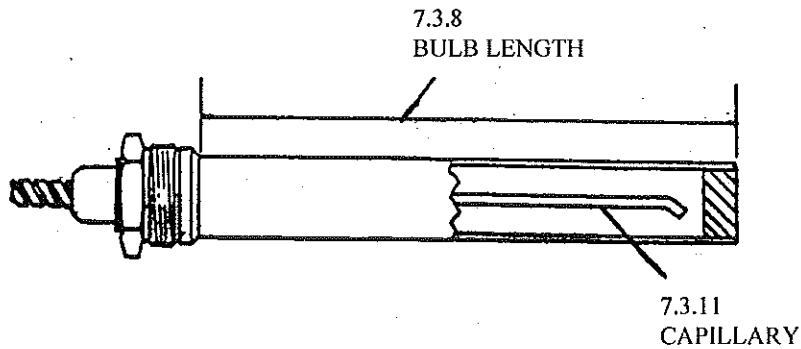

Figure 17

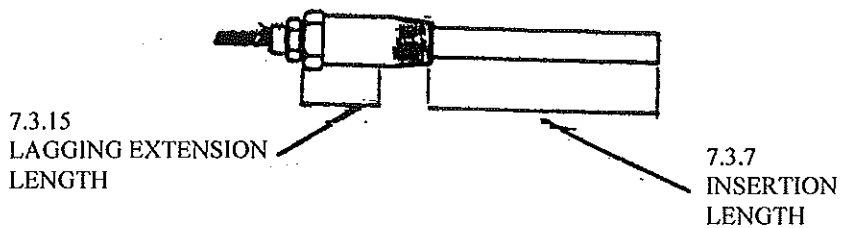

Figure 18

7.3.223 Union Connected Bulb Assembly -- A union bulb and means, such as a bushing, flange or well, for pressure tight attachment to a vessel. See Fig. 19.

7.3.234 Union Connection -- That portion of a union connected bulb which comprises a seating part either rigidly attached to or adjustable along the extension and a jam nut for attachment to a bushing flange or well.

7.3.254 Well -- A pressure tight receptacle adapted to receive a union connected bulb and provided with external threads (NPT) or other means for pressure tight attachment to a vessel. See Fig. 19.

7.3.265 Well Length -- The length of the bulb plus $\frac{1}{4}$ ". This is an inside measurement from the bottom of the bulb seat to the end of the well.

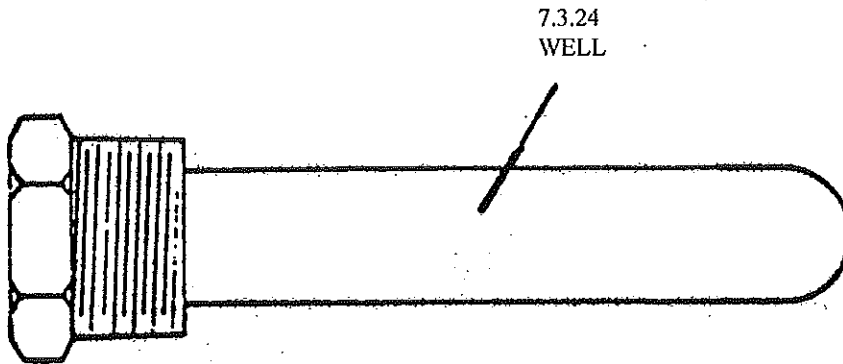

Figure 19

8 DESIGN FEATURES

8.1 Anti-Cavitating Trim -- Regulator trim designed to reduce the effects of cavitating service.

8.2 Balanced -- A regulator style featuring a pressure balanced plug. May be single or double seated.

8.3 Cage Guided -- A regulator that utilizes a cage for plug guiding.

8.4 Direct Action -- A regulator that increases its output as the measured variable increases.

8.5 Double Seated -- A regulator style featuring a plug with two seats.

8.6 End Connection -- The configuration provided to make a pressure tight joint to the pipe carrying the fluid to be controlled.

8.7 End-to-End Dimension -- See 8.8, Face to Face Dimensions.

8.8 Face-to-Face Dimension -- The dimension from the face of the inlet opening to the face of the outlet opening of the regulator.

8.9 Flange Facing -- The finish on the end connection gasket surfaces of flanged valves.

8.10 Hard Facing -- A material harder than the surface to which it is applied. Used to resist galling or fluid erosion.

8.11 Noise Attenuation Trim -- Regulator trim that is designed to minimize the noise of gas or steam flow.

8.12 Packless -- A construction that does not employ a dynamic seal isolating internal fluid from ambient or atmosphere.

8.13 Reverse Action -- A regulator that decreases its output as the measured variable increases.

8.14 Semi-balanced -- A regulator style where the plug is partially pressure balanced.

8.15 Single Seated -- A regulator style having a plug with a single seat.

8.16 Soft Seat -- An elastomeric, plastic, or other readily deformable material used either in the valve plug or seat ring to provide tight shut-off with

minimal force -- See ANSI/FCI 70-3 as a reference for leakage class.

8.17 Unbalanced -- A regulator where the plug is not pressure balanced. Generally a single seated regulator.

9 GLOSSARY OF NON-STANDARD TERMS

This section's purpose is to provide a means of relating the various non-standard terms to preferred terms.

9.1 Bubble Tight -- A leakage classification. Refer to ANSI/FCI 70-3 for preferred leakage classification.

9.2 Dead End Buildup -- See Lockup 6.14.

9.2.1 Dead End Shut Off -- Refer to ANSI/FCI 70-3 for specification of leakage classifications.

9.3 Driptight -- A leakage classification. Refer to ANSI/FCI 70-3 for preferred leakage classification.

9.4 Droop -- See Accuracy of Regulation 6.2.

9.5 Droptight -- A leakage classification. Refer to FCI 70-2-1998 for preferred leakage classification.

9.6 Offset -- See Accuracy of Regulation 6.2.

10 REFERENCES

A number of technical societies, trade associations and government agencies in the United States promulgate codes, standards or specifications which contain terminology pertinent to regulators. Approximately 40 sources were contacted and of those responding the following were sources of pertinent existing terminology.

Instrument Society of America

- ISA S75.01.01 Control Valve Sizing Equations
- ISA RP41 Uniform Face-to-Face Dimensions for Flanged Control Valve Bodies
- ISA S51.1 Process Instrument Terminology
- ISA S75.05 Control Valve Terminology

National Fluid Power Association

- NFPA/T2.1.1 RI Fluid Power Systems and Products Glossary

American National Standards Institute

- ANSI B95.1 Terminology for Pressure Relief Devices

Scientific Apparatus Makers Association

- PMC 20-2 Process Measurement and Control Terminology